

VERTICAL LOCKER

BASE INSTRUCTIONS

Flat and firm base. Recommended: concrete, tarmac or paving flags.
 Min. distance from walls/ shrubbery: 1000mm.
 Min. base size (WxDxH) 1200mm x 1000mm x 50mm.

LEVELING THE UNIT

Correctly level the constructed unit using the shims (ZCOMPPLAS) provided prior to fixing the unit to the ground. Slide the packing pieces under the corners of the unit base as required until an equal gap has been achieved around the door allowing for its smooth operation and alignment.

It is always recommended to anchor the unit to the ground. Drill through the four holes in the base of the unit using 6mm dia masonry drill to a depth of 70mm. Screw in the anchor fixings. (These have a self cutting thread). If not anchoring the unit, fit the self seal plugs BEFORE BUILDING to block the fixing holes from underneath. **Please note product must be anchored down to comply with LPS1175.**

TOOLS REQUIRED

Power driver POSI-DRIV screwdriver, 6mm dia. masonry drill and a 10mm socket or spanner.

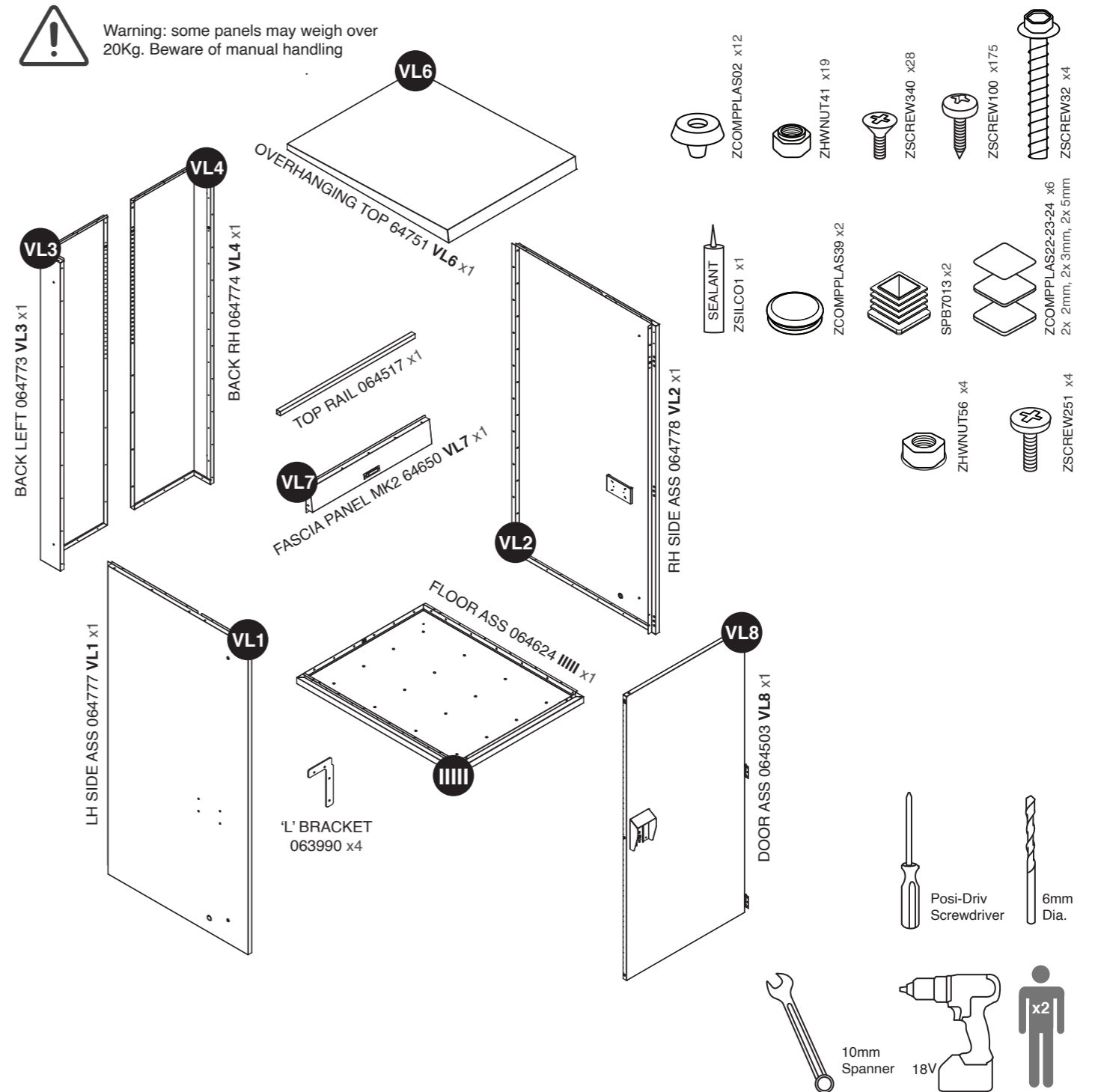

PLEASE NOTE ALL SCREWS ARE FIXED FROM THE INSIDE

1! SECURE RIGHT HAND SIDE PANEL (VL2) TO FLOOR (IIIII) WITH ZSCREW100.

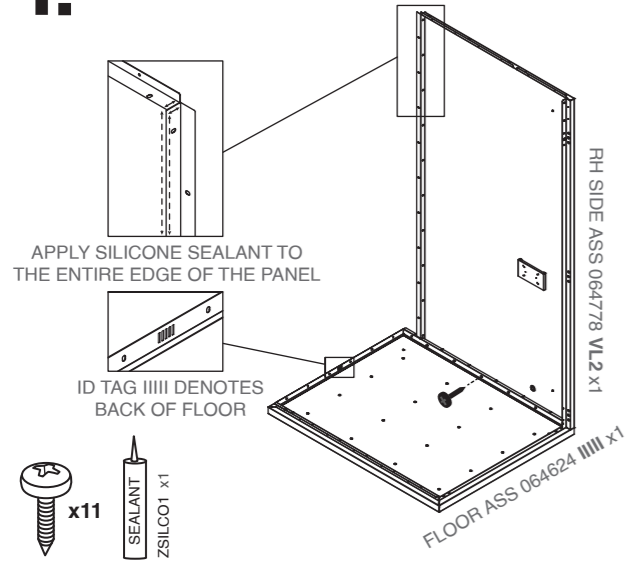

2! SECURE RIGHT HAND BACK PANEL (VL4) TO BASE & SIDE PANEL WITH ZSCREW100.

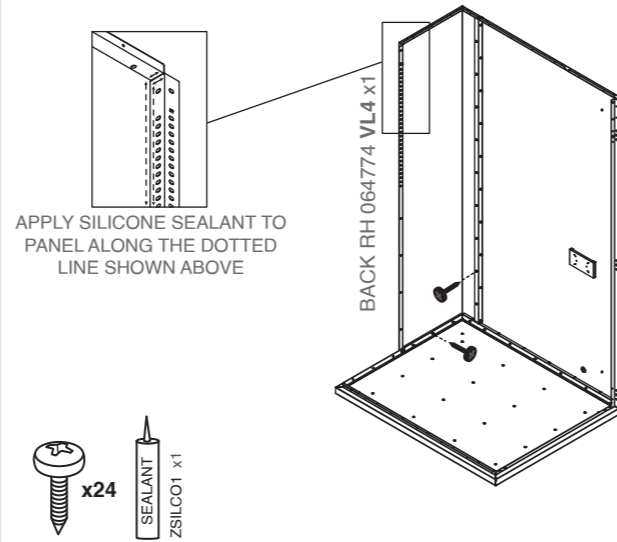

7! POSITION OVERHANGING TOP (VL6) AND SECURE WITH 25 ZSCREW100.

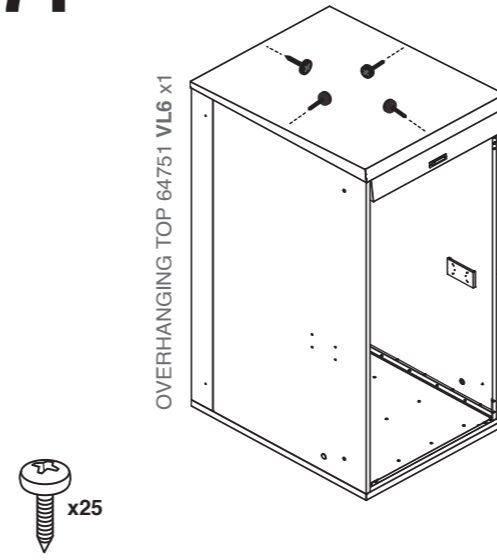

8! POSITION DOOR (VL8) AND SECURE WITH 9 ZSCREW340.

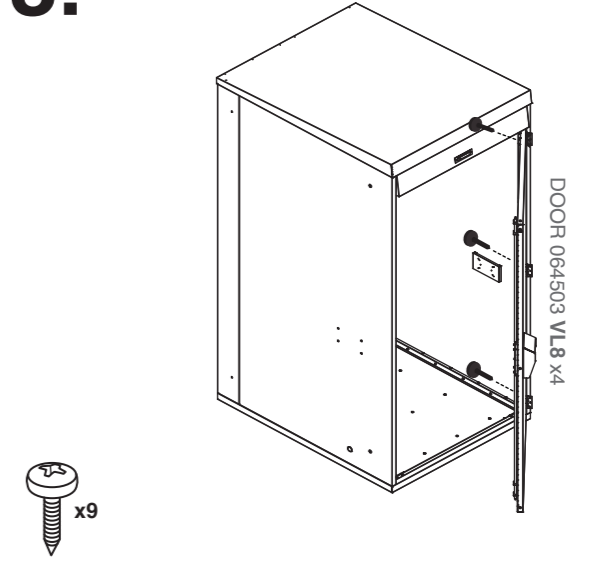

3! SECURE LEFT HAND SIDE PANEL (VL1) TO BASE WITH 11 ZSCREW100.

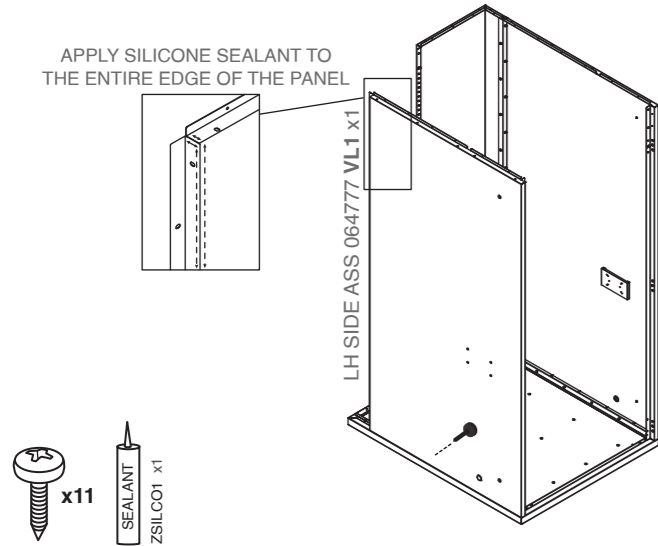

4! SECURE LEFT HAND BACK PANEL (VL3) TO BASE WITH 35 ZSCREW100.

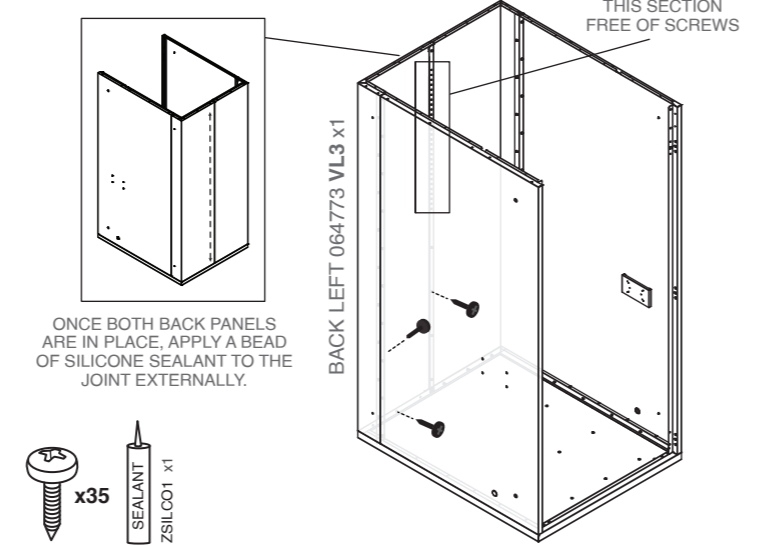

9! ENSURE THE BIKE LOCKER IS LEVEL USING SHIMS. THE DOOR WILL CLOSE CORRECTLY IF SO.

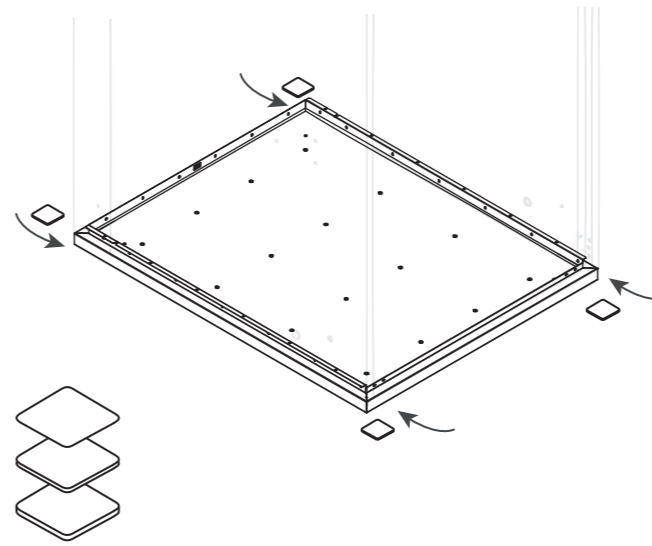

10! ONCE LEVEL, FILL FOUR FIXING HOLES WITH SILICONE SEALANT THEN SECURE LOCKER TO THE GROUND WITH 4 ZSCREW32

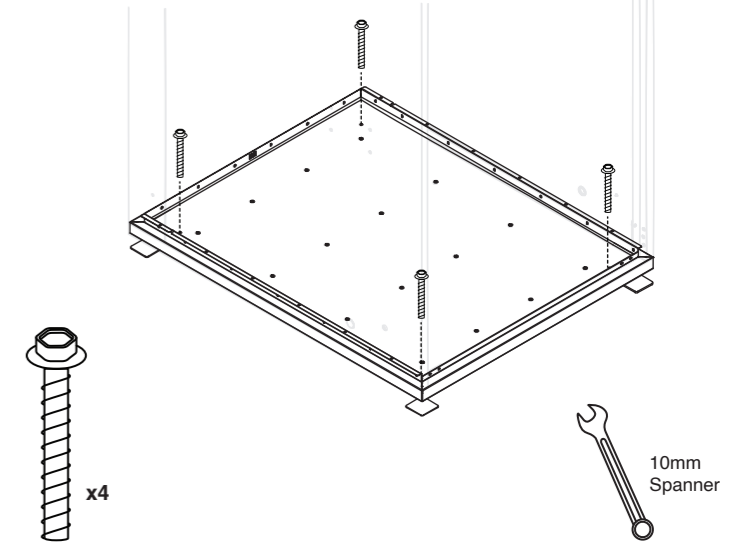

5! FIT FASCIA PANEL (VL7) USING 4 ZSCREW100.

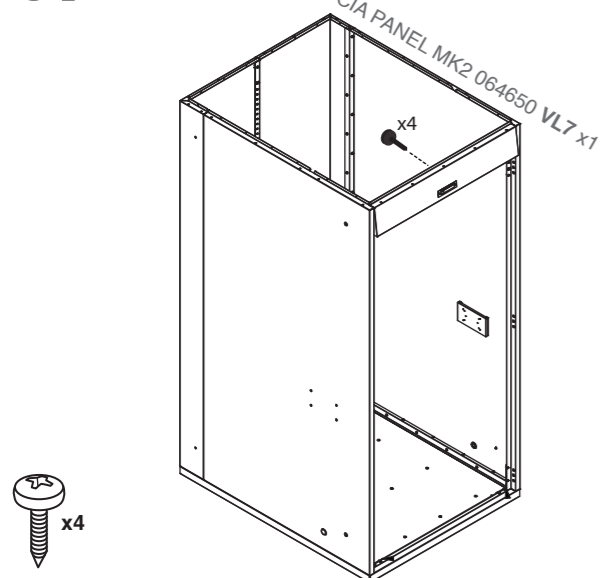

6! POSITION 1 'L' BRACKET IN EACH CORNER OF THE DOOR OPENING. SECURE WITH 16 ZHWNUT41 AND 16 ZSCREW340.

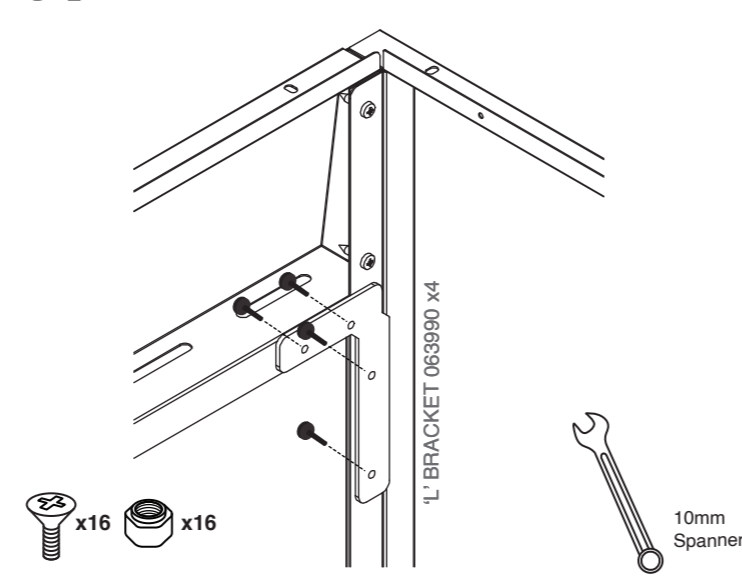

11! PLACE TOP RAIL IN 2 SIDE CUT OUTS.

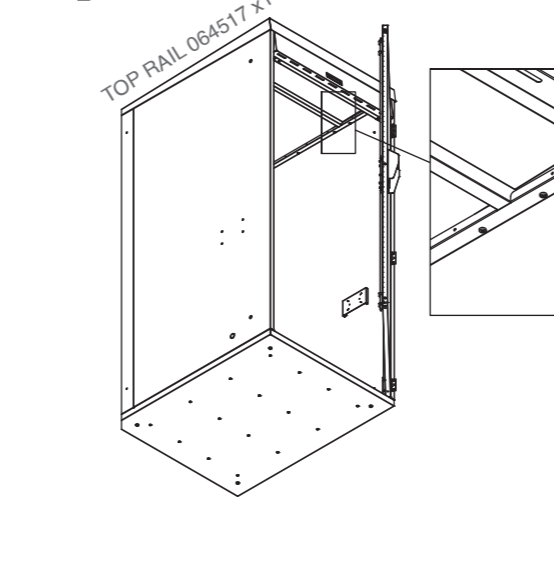

12! IF PLACING MULTIPLE UNITS SIDE BY SIDE, FASTEN THE UNITS TOGETHER WITH 4 ZSCREW251 AND 4 ZHWNUT56.

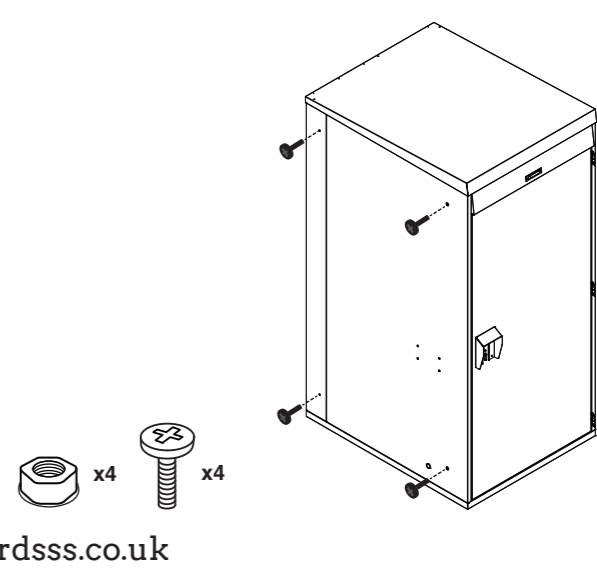

www.asgardsss.co.uk