

SENTRY E SHED

BASE INSTRUCTIONS

Flat and firm base. Recommended: concrete, tarmac or paving flags.
 Min. distance from walls/ shrubbery: 1000mm.
 Min. base size (WxDxH) 2400mm x 1200mm x 50mm.

LEVELING THE UNIT

Correctly level the constructed unit using the shims (ZCOMPPLAS) provided prior to fixing the unit to the ground. Slide the packing pieces under the corners of the unit base as required until an equal gap has been achieved around the door allowing for its smooth operation and alignment.

It is always recommended to anchor the unit to the ground. Drill through the four holes in the base of the unit using 6mm dia masonry drill to a depth of 70mm. Screw in the anchor fixings. (These have a self cutting thread). If not anchoring the unit, fit the self seal plugs BEFORE BUILDING to seal the fixing holes from underneath.

TOOLS REQUIRED

Power driver POSI-DRIV screwdriver, 6mm dia. masonry drill, a 10mm socket or spanner.



Warning: some panels may weigh over 20Kg. Beware of manual handling

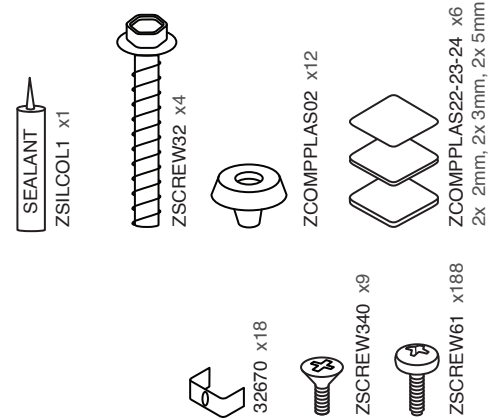
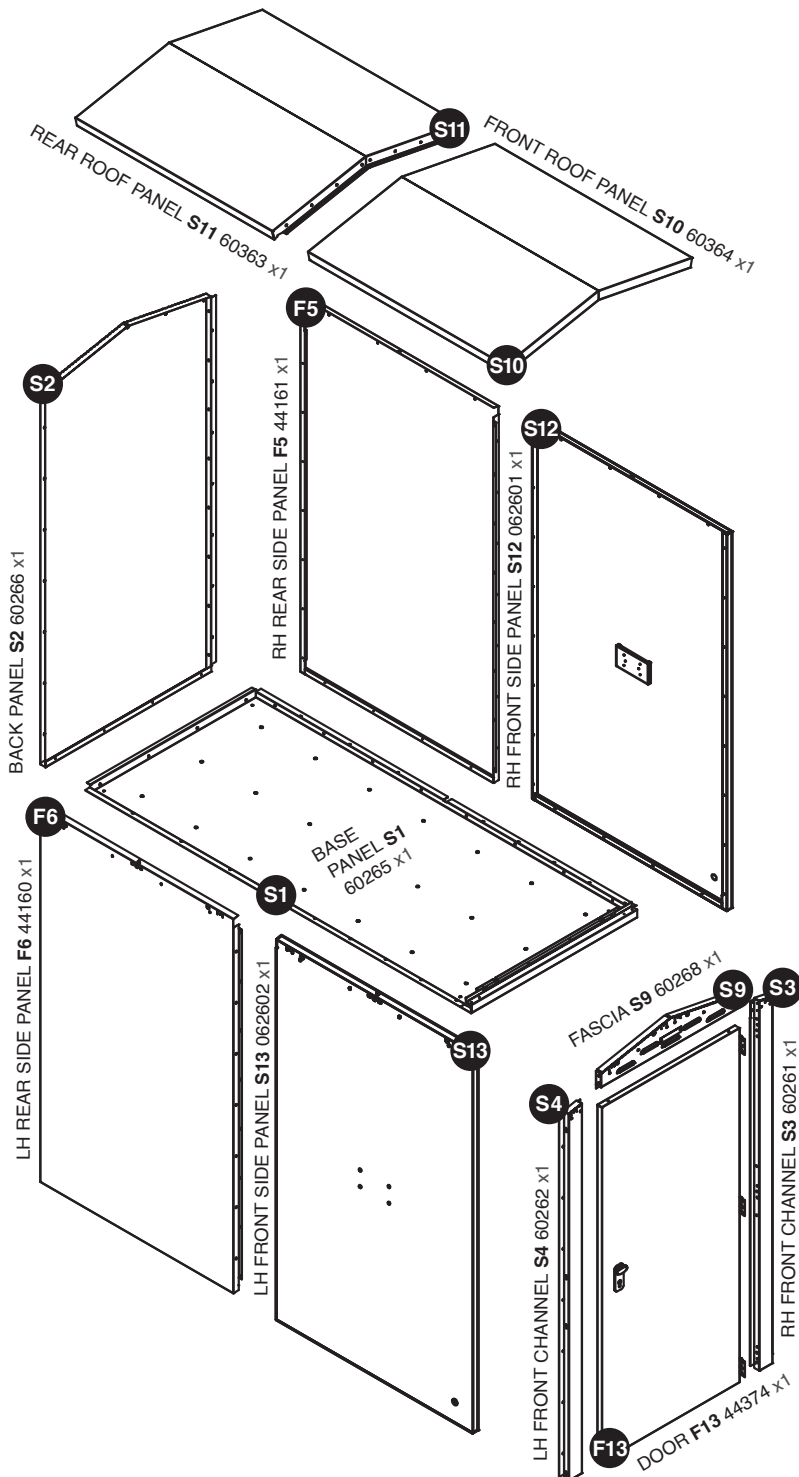

Warning: Please keep this key card safe! Refer to if replacement key is required.

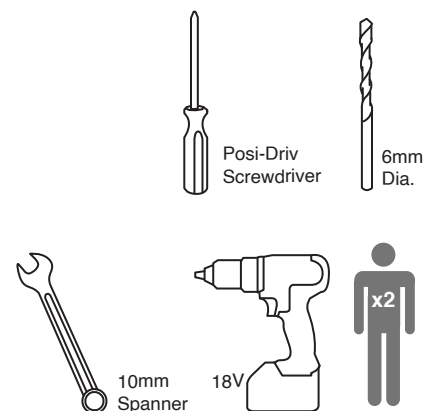

PLEASE NOTE ALL SCREWS ARE FIXED FROM THE INSIDE

1

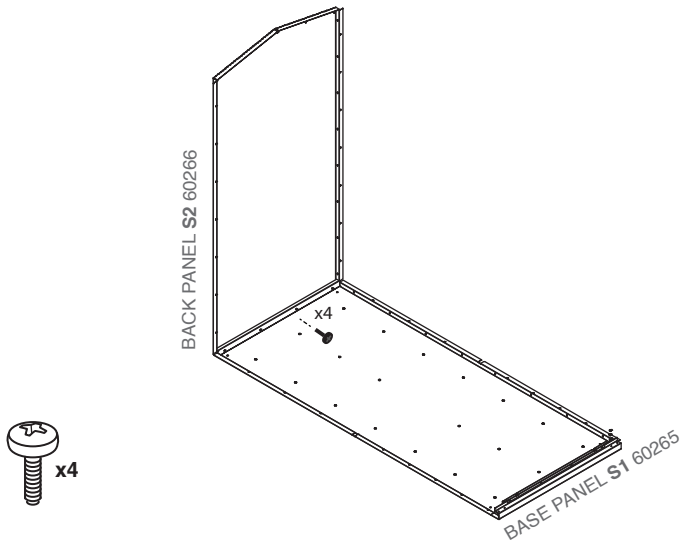

2

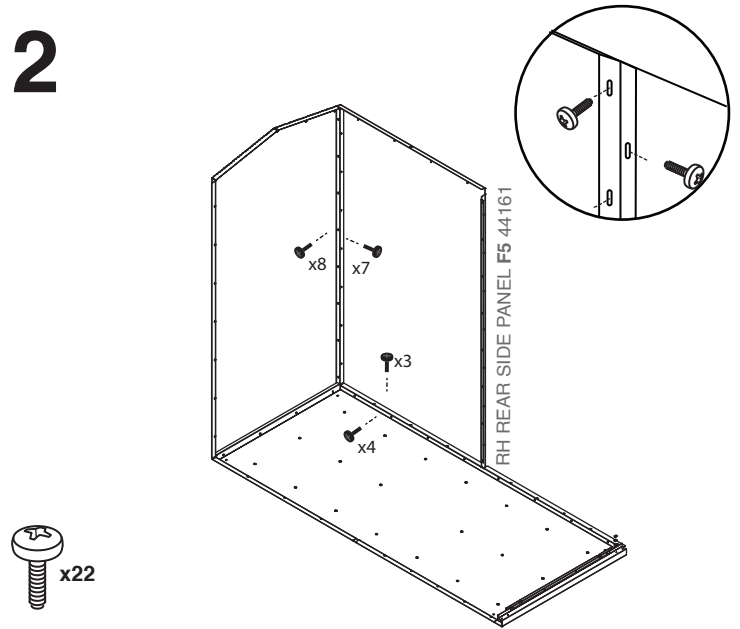

3

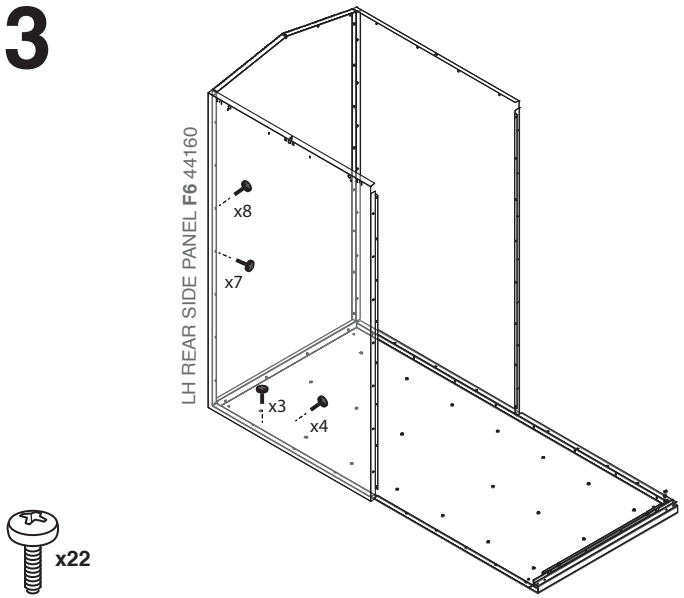

4

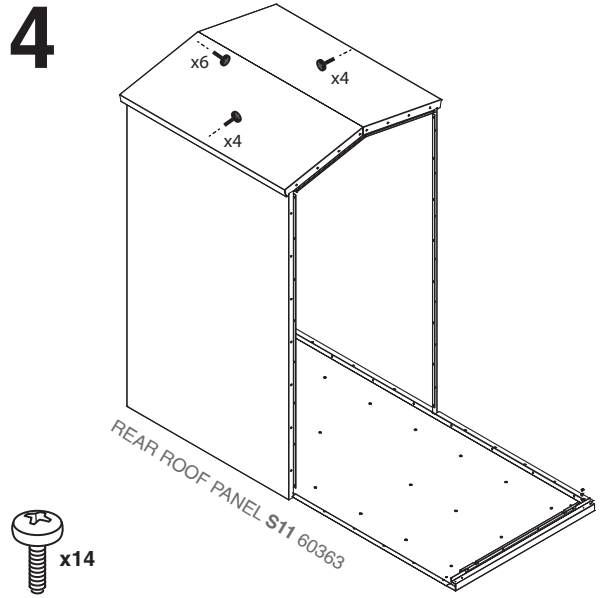

5

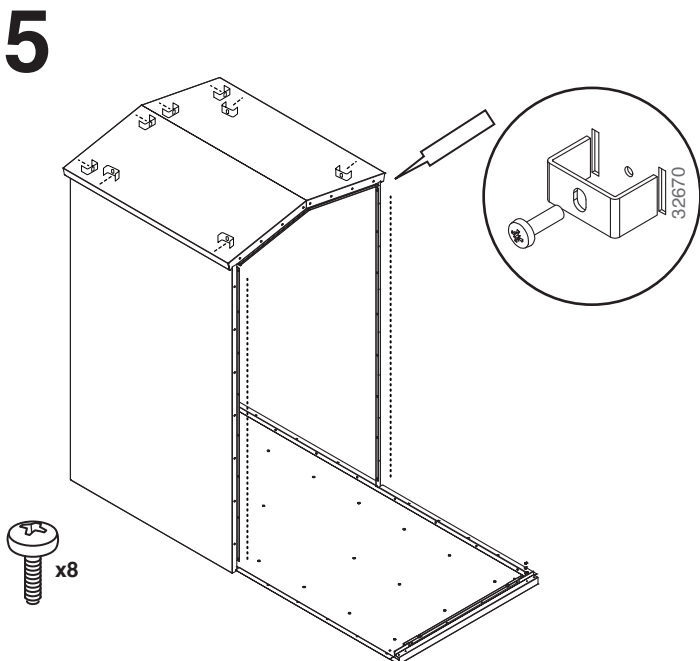

6

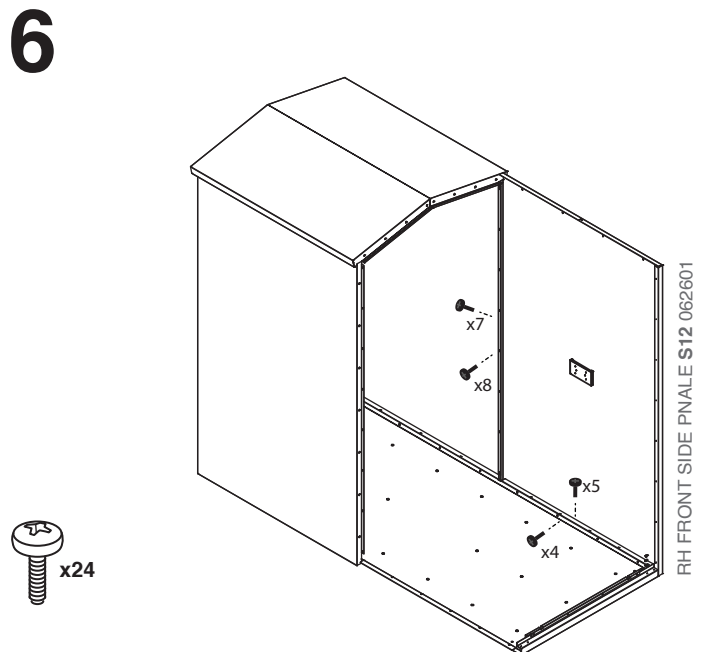

7! RUN A CONTINUOUS BEAD OF SILICONE UP THE VERTICAL FRONT JOINTS & ALONG THE TOP EDGE OF BASE WHERE IN CONTACT WITH THE FRONT CHANNELS

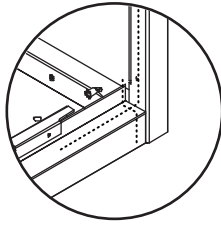

LH FRONT SIDE PANEL S13 062602

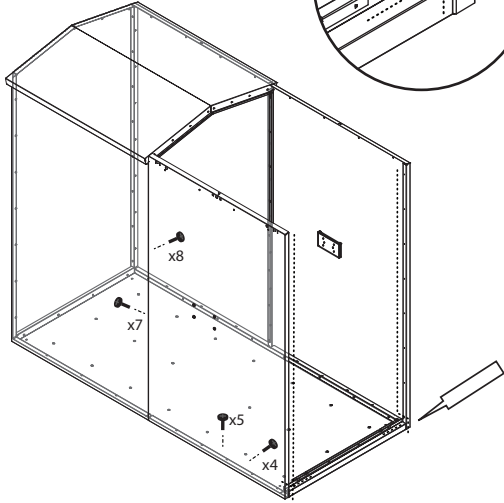

8! PARTIALLY SCREW IN A ZSCREW61 INTO HOLES 1, 4, 5 & 8 ON BOTH SIDES OF THE SHED, LEAVING A GAP OF 5MM

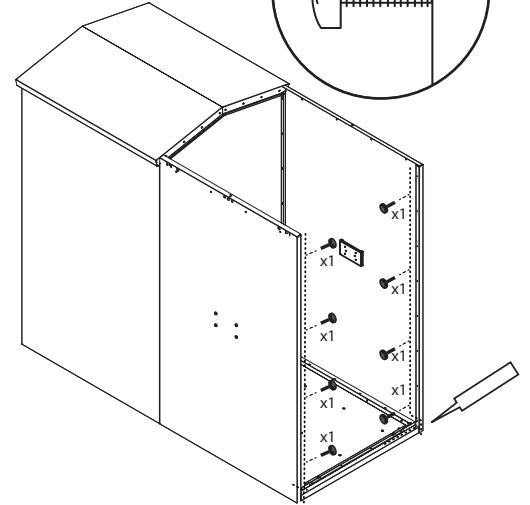
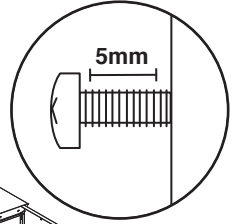

9! PLACE CHANNELS OVER SCREWS AND DROP INTO PLACE

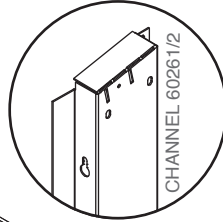

LH FRONT CHANNEL S4 60262
RH FRONT CHANNEL S3 60261

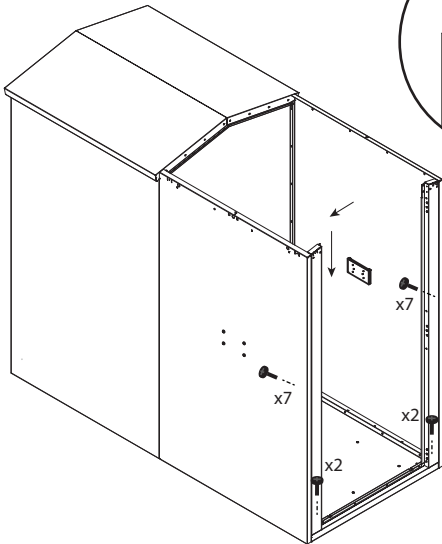

10! TIGHTEN SCREWS FROM STEP 8 THROUGH THE ACCESS HOLES

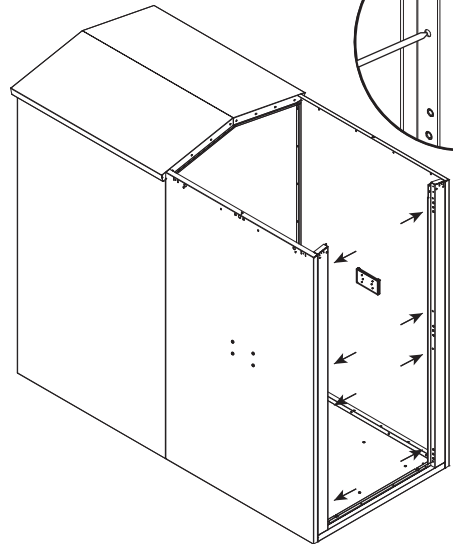
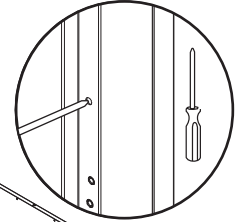

11! SEAL ACCESS HOLES WITH ZCOMPPLAS02

ZCOMPPLAS02

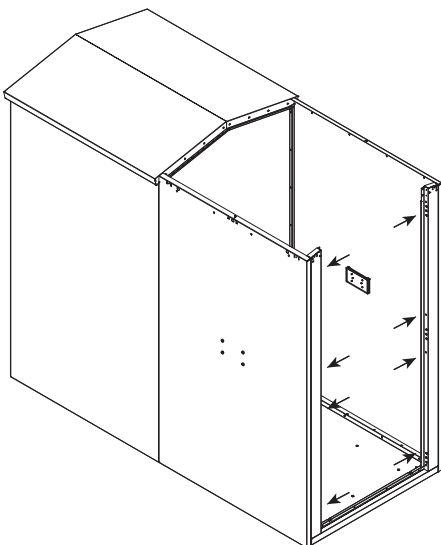

12

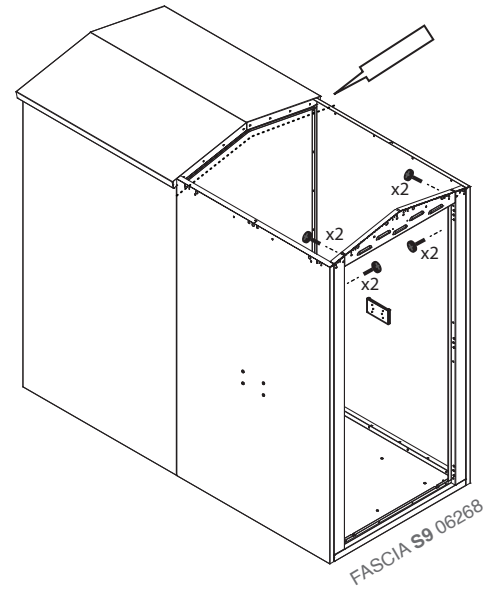

FASCIA S9 06268

13

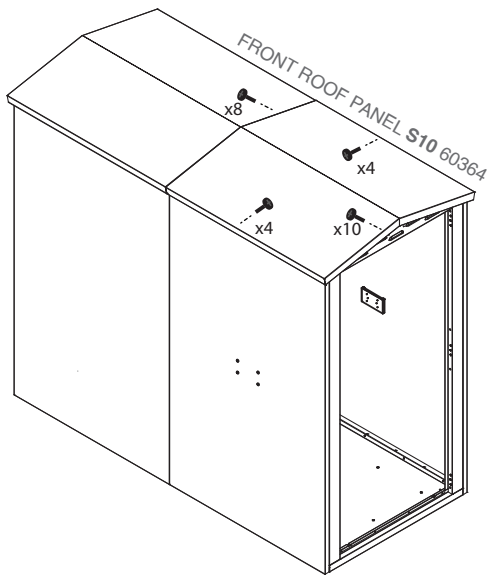

14

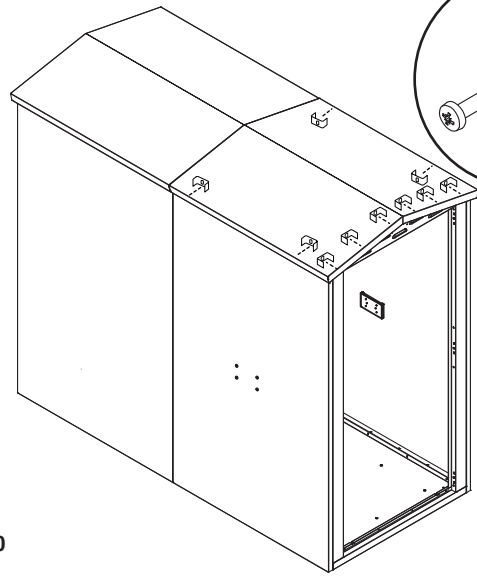

15

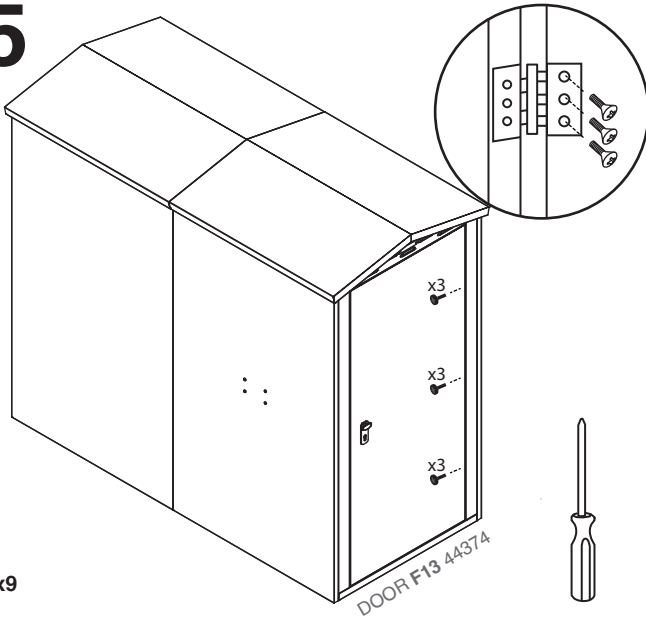

16!

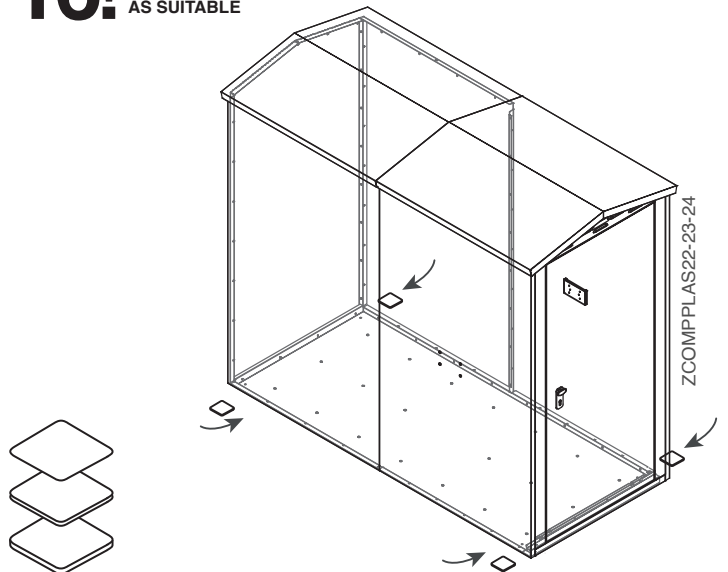
 LEVEL SHED UNTIL DOORS ALIGN USING ZCOMPPLAS AS SUITABLE

17

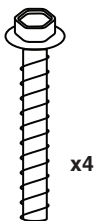
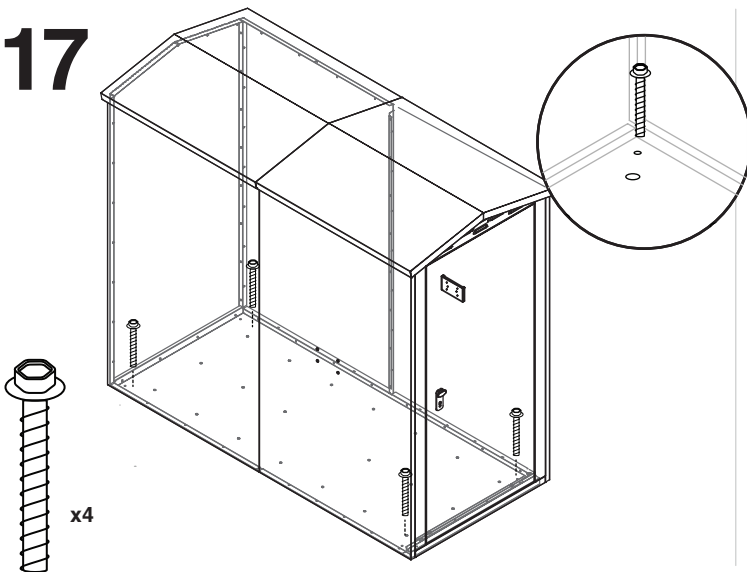

18!

 SEAL ALL INTERNAL CORNERS