

## FLEXISTORE 1522

### BASE INSTRUCTIONS

Flat and firm base. Recommended: concrete, tarmac or paving flags.  
Min. distance from walls/ shrubbery: 1000mm.  
Min. base size (WxDxH) 1730mm x 2640mm x 50mm.

### LEVELING THE UNIT

Correctly level the constructed unit using the shims (ZCOMPPLAS) provided prior to fixing the unit to the ground. Slide the packing pieces under the corners of the unit base as required until an equal gap has been achieved around the door allowing for its smooth operation and alignment.

It is always recommended to anchor the unit to the ground. Drill through the four holes in the base of the unit using 6mm dia masonry drill to a depth of 70mm. Screw in the anchor fixings. (These have a self cutting thread). If not anchoring the unit, fit the self seal plugs BEFORE BUILDING to seal the fixing holes from underneath.

### TOOLS REQUIRED

Power driver POSI-DRIV screwdriver, 6mm dia. masonry drill, a 10mm socket or spanner.

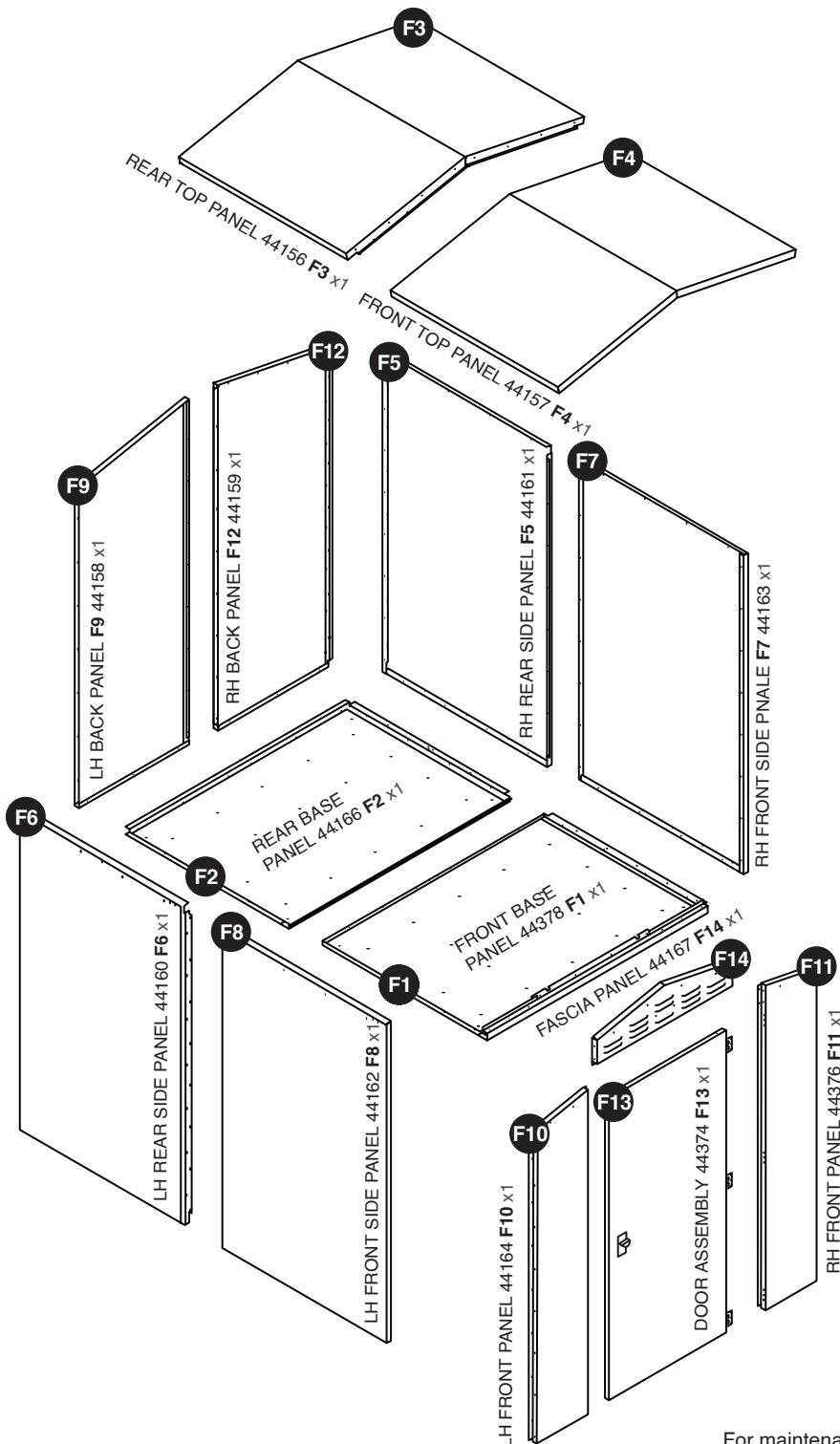

Warning: some panels may weigh over 20Kg. Beware of manual handling

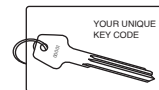
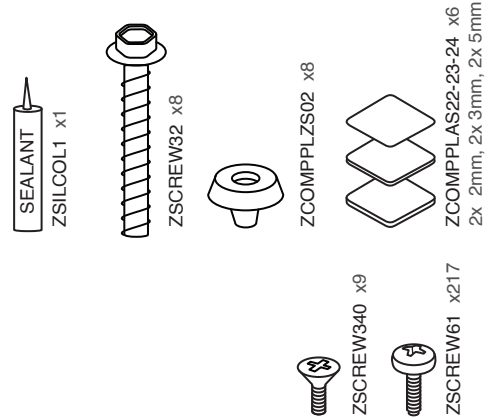

Warning: Please keep this key card safe! Refer to if replacement key is required.

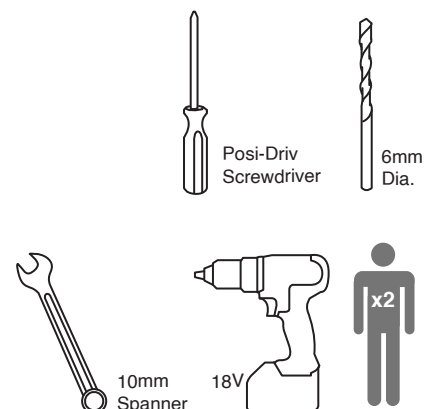

PLEASE NOTE ALL SCREWS ARE FIXED FROM THE INSIDE

**1!** IF YOU HAVE AN OPTIONAL RAMP, PLACE UNDERNEATH FRONT BASE PANEL AT THIS STAGE

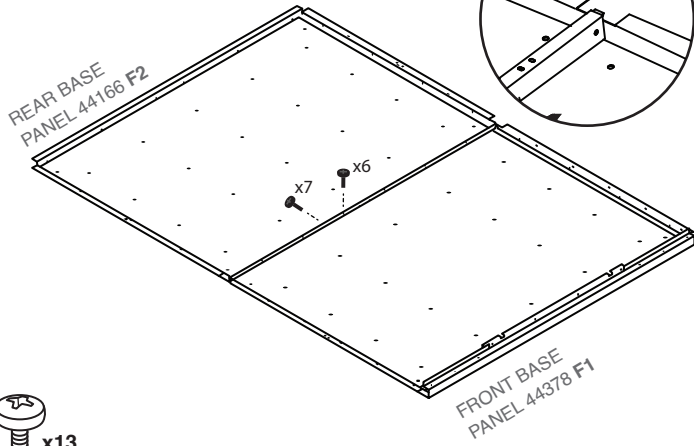

**2**

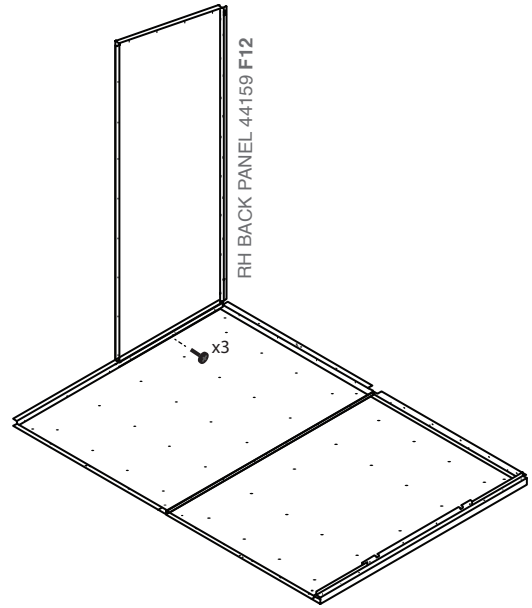

**3**

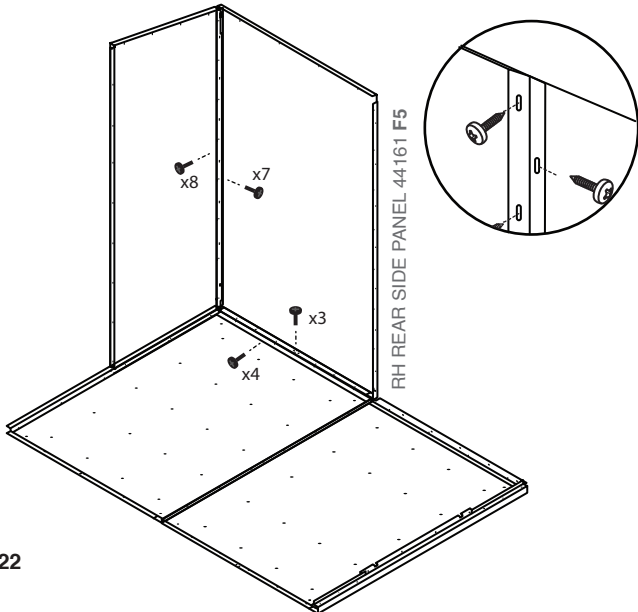

**4**

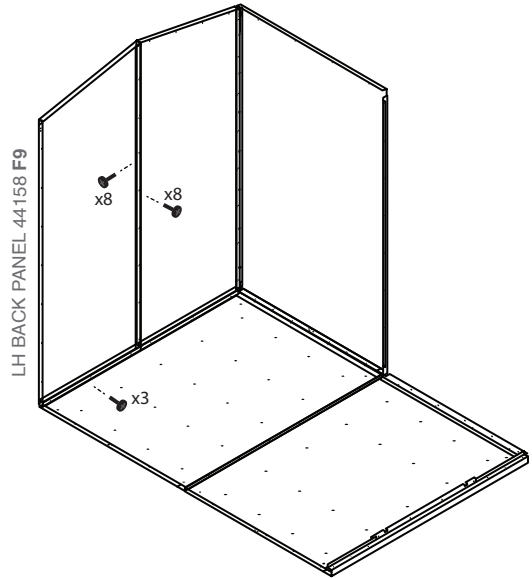

**5**

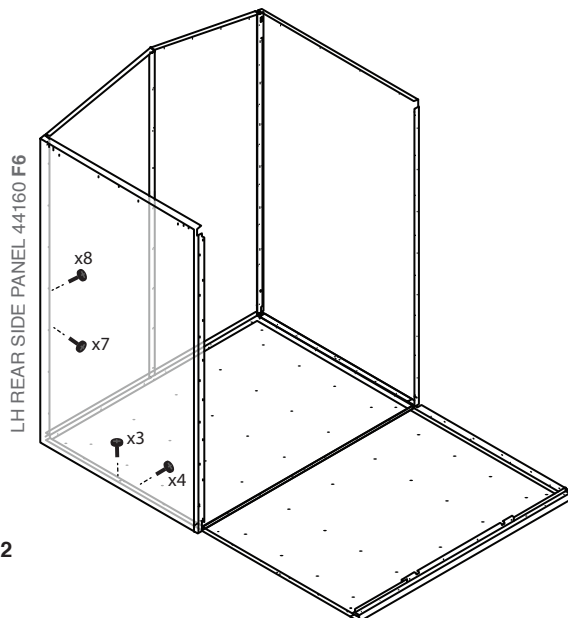

**6**

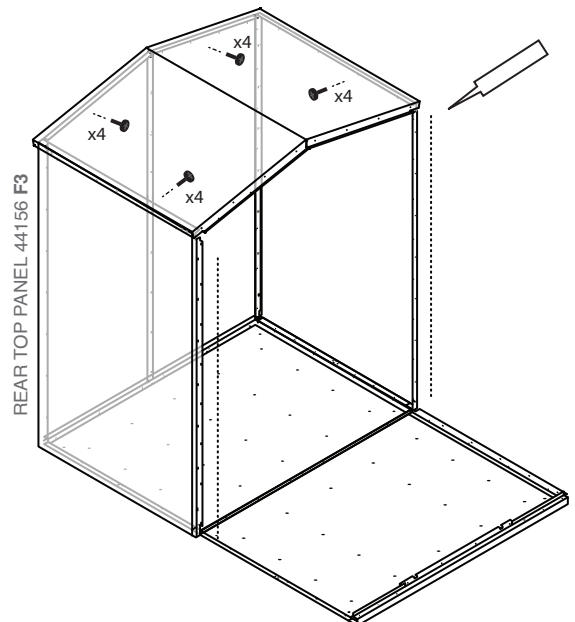

7

RH FRONT SIDE PNALE 44163 F7

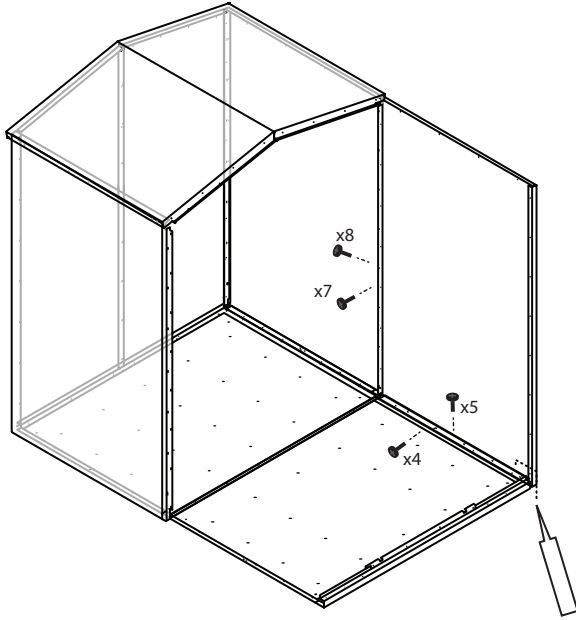

8

RH FRONT PANEL 44376 F11

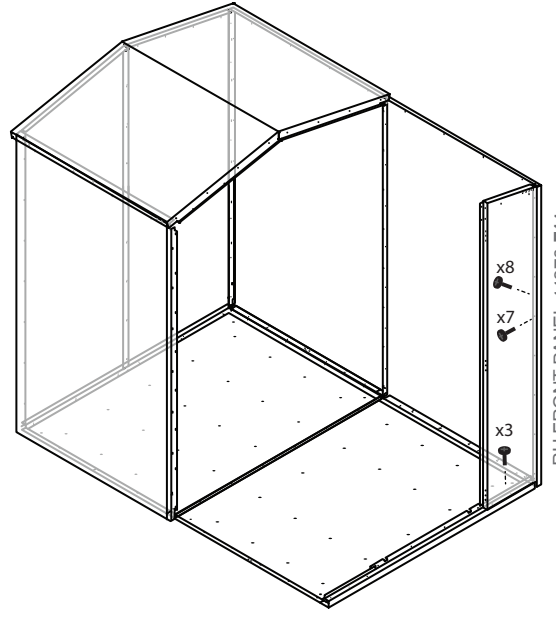

9

LH FRONT SIDE PANEL 44162 F8

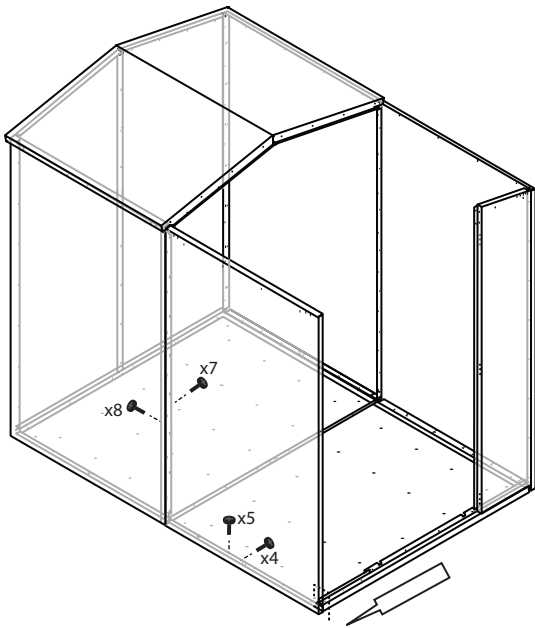

10

LH FRONT PANEL 44164 F10

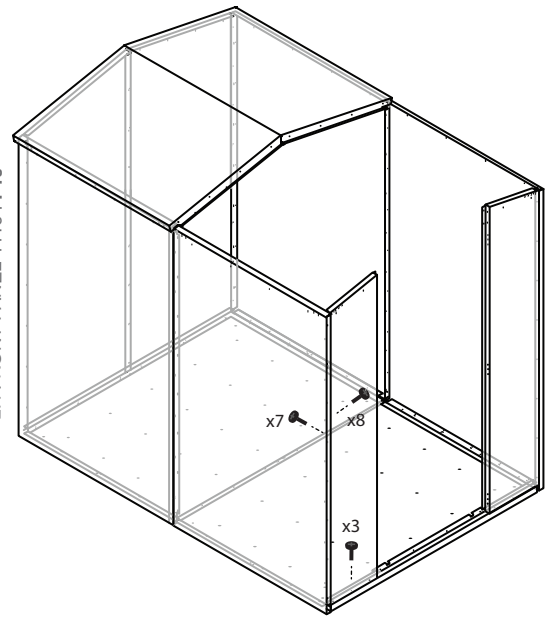

11

FASCIA PANEL 44167 F14

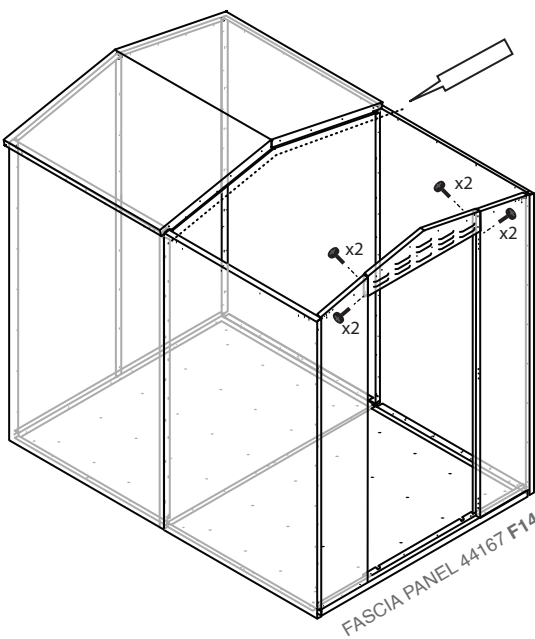

12

FRONT TOP PANEL 44157 F4

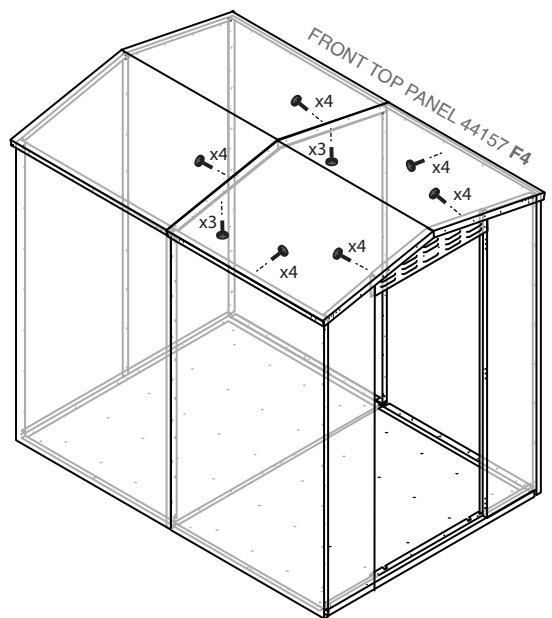

# 13

DOOR ASSEMBLY 44374 F13

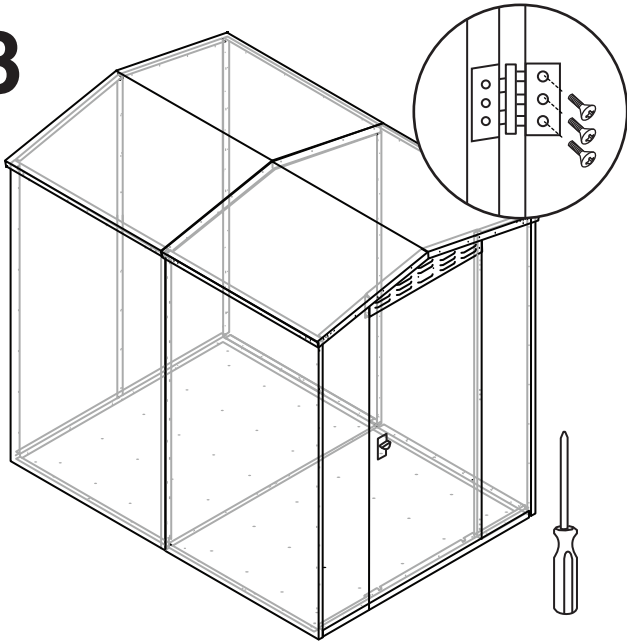

# 14!

LEVEL SHED UNTIL DOORS  
ALIGN USING ZCOMPLAS  
AS SUITABLE

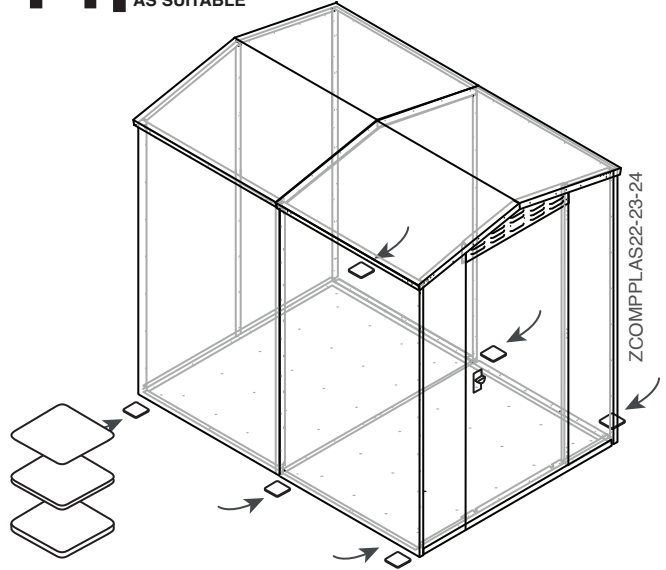

# 15

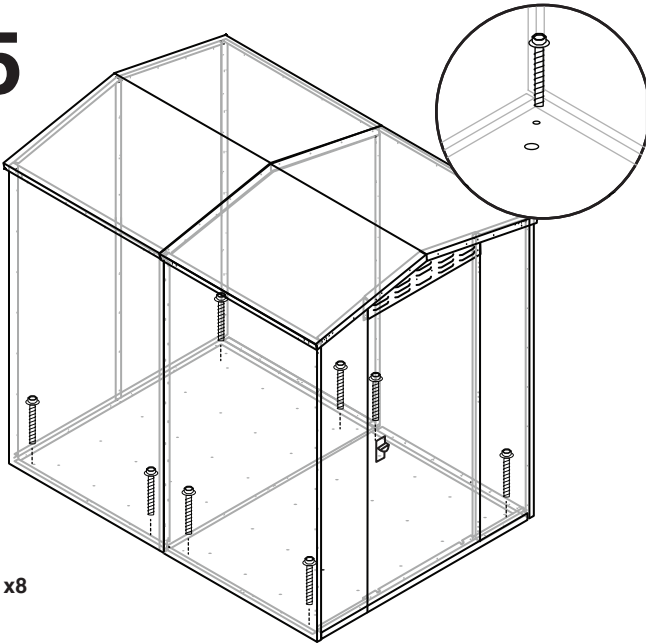
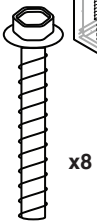

# 16!

SEAL ALL INTERNAL  
CORNERS

