

ACCESS PLUS

BASE INSTRUCTIONS

Flat and firm base. Recommended: concrete, tarmac or paving flags.
Min. distance from walls/ shrubbery: 1000mm.
Min. base size (WxDxH) 2450mm x 1150mm x 50mm.

LEVELING THE UNIT

Correctly level the constructed unit using the shims (ZCOMPPLAS) provided prior to fixing the unit to the ground. Slide the packing pieces under the corners of the unit base as required until an equal gap has been achieved around the door allowing for its smooth operation and alignment.

To maintain a level shed, the unit **must** be bolted to the ground. Drill through the four holes in the base of the unit using 6mm dia masonry drill to a depth of 70mm. Screw in the anchor fixings. (These have a self cutting thread). **If not anchoring the unit, fit the 4 self-seal plugs BEFORE BUILDING to block the fixing holes underneath. Fit 4 self-seal plugs in the side of base to stop water from entering the unit.**

TOOLS REQUIRED

Power driver POSI-DRIV screwdriver, 6mm dia. masonry drill and a 8mm, 10mm & 13mm socket or spanner.



Warning: some panels may weigh over 20Kg. Beware of manual handling

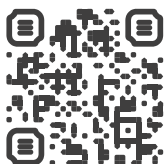
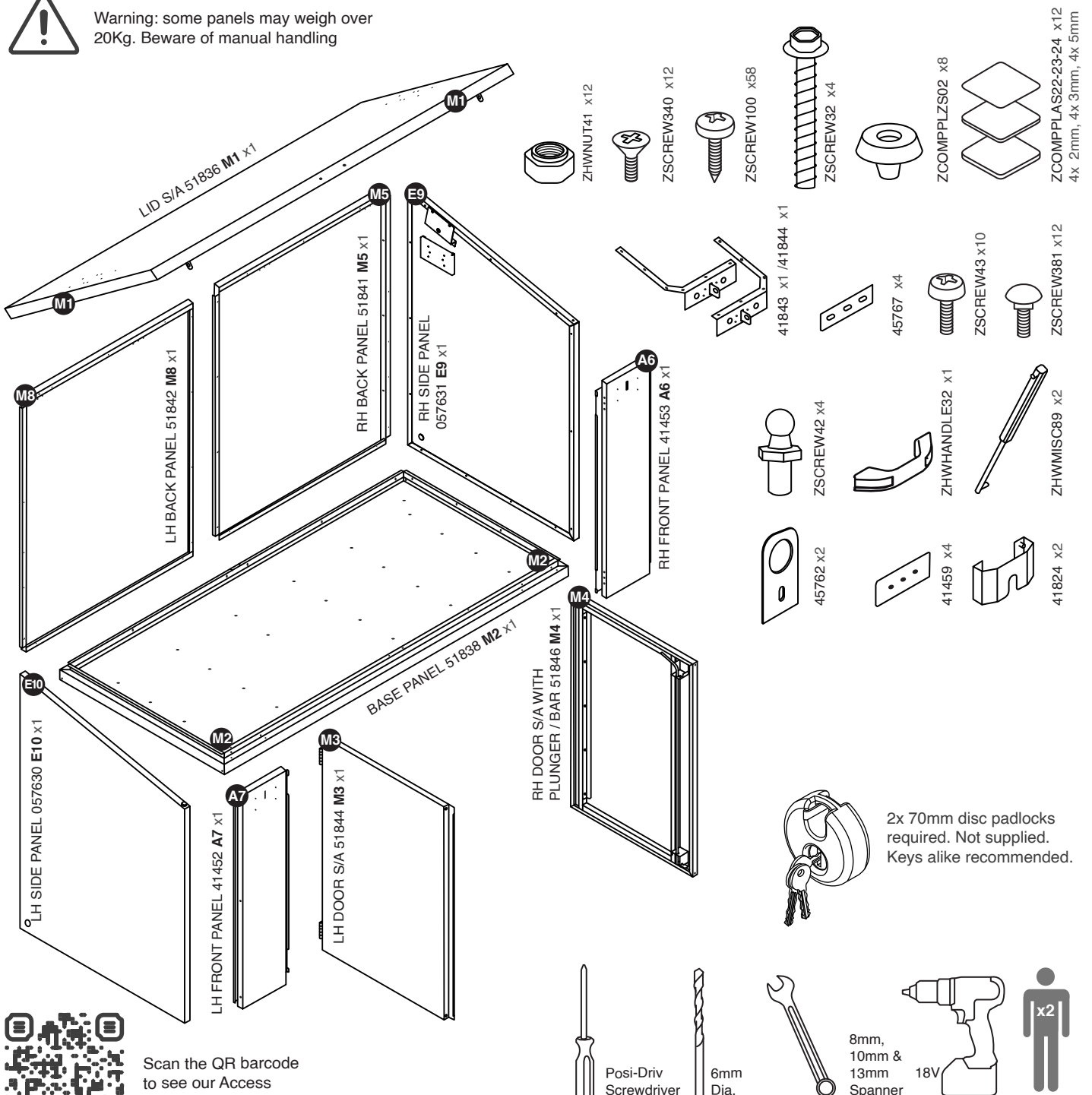

Scan the QR barcode to see our Access 'How To' help videos

PLEASE NOTE ALL SCREWS ARE FIXED FROM THE INSIDE

1! IF YOU HAVE AN OPTIONAL RAMP, PLACE UNDERNEATH FRONT BASE PANEL AT THIS STAGE

! FIT SELF-SEAL PLUGS: 4X SIDE OF BASE. 4X BOTTOM OF BASE IF UNIT IS NOT BEING SECURED TO FLOOR

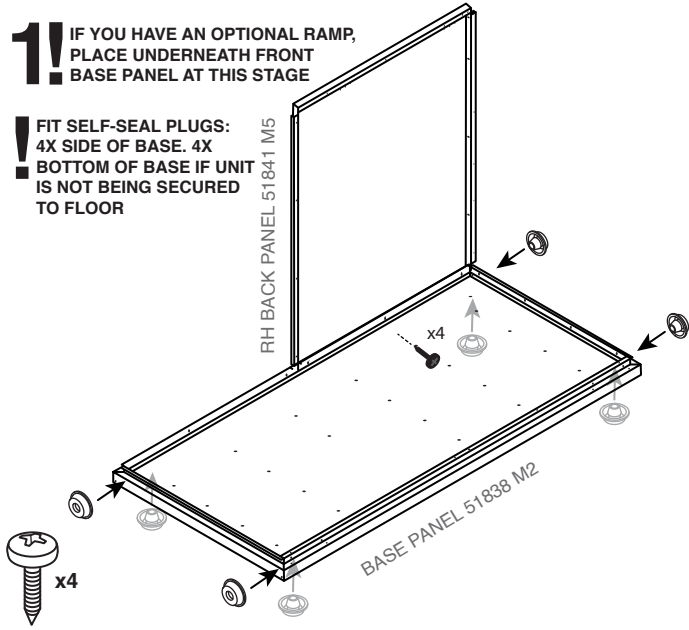

2

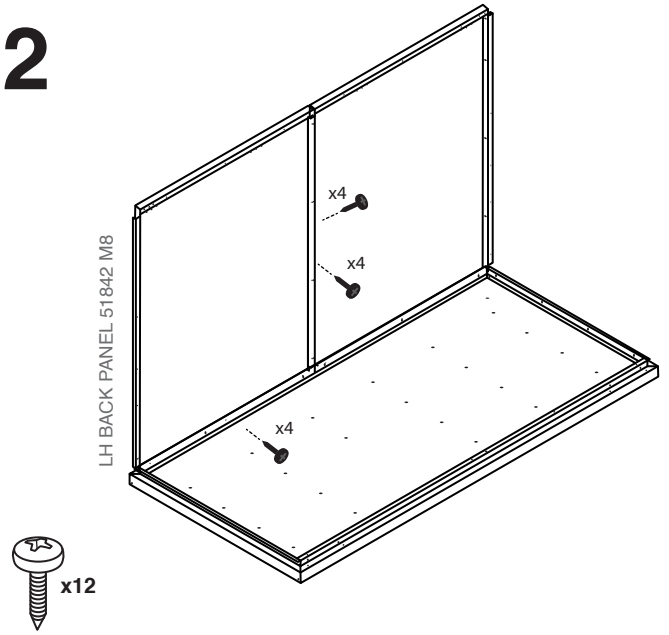

3

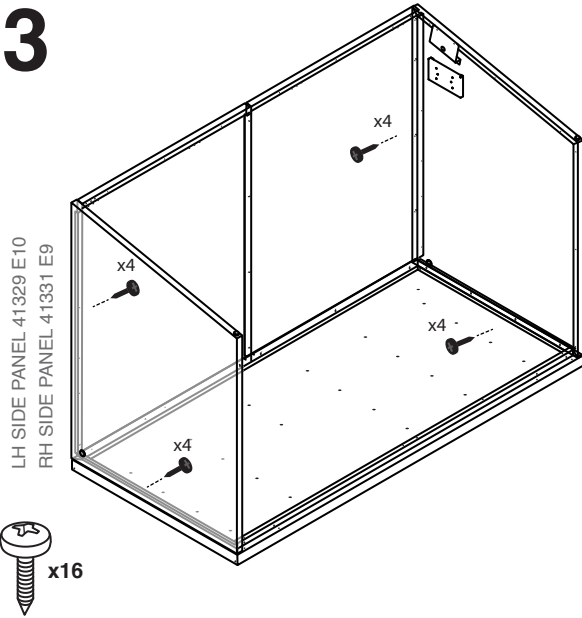

4

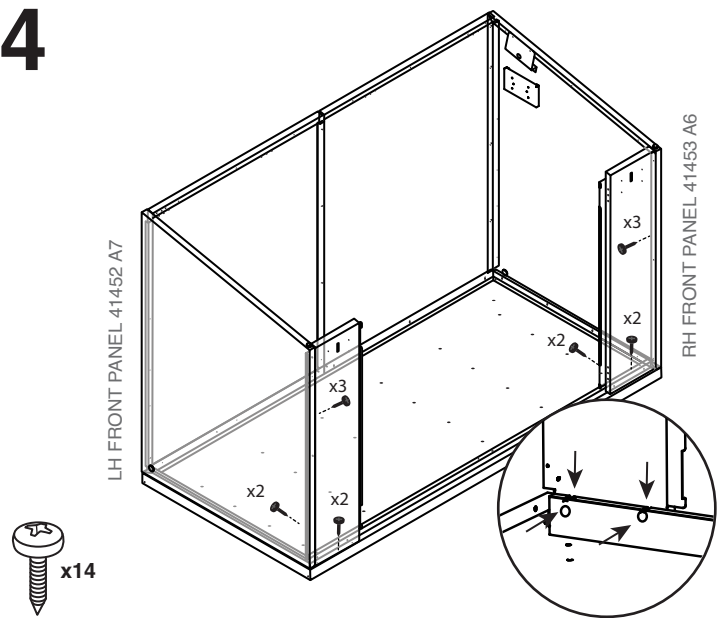

5

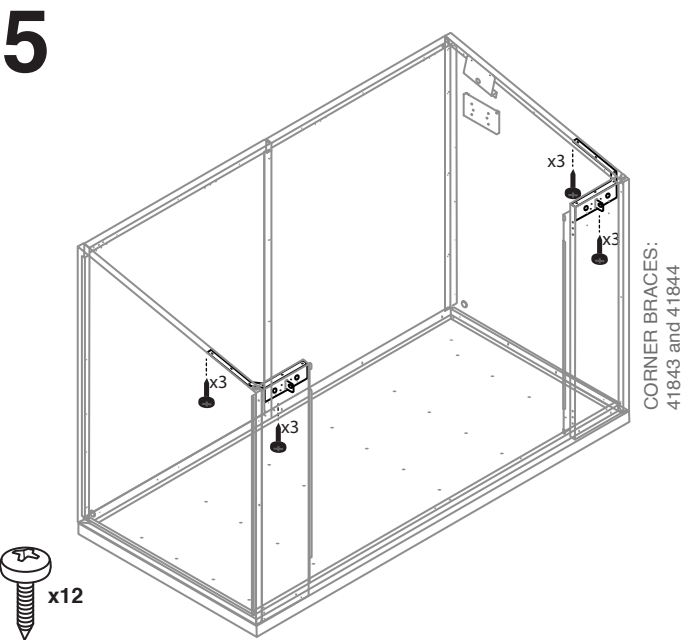

6

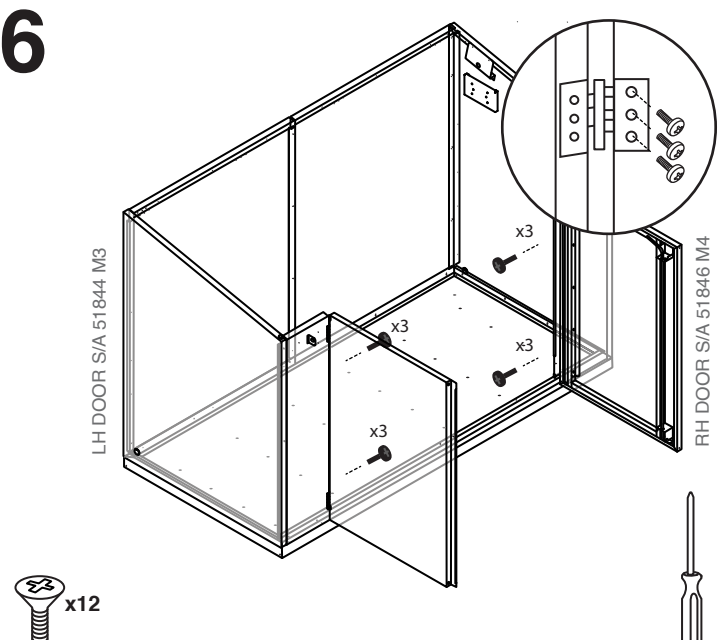

7

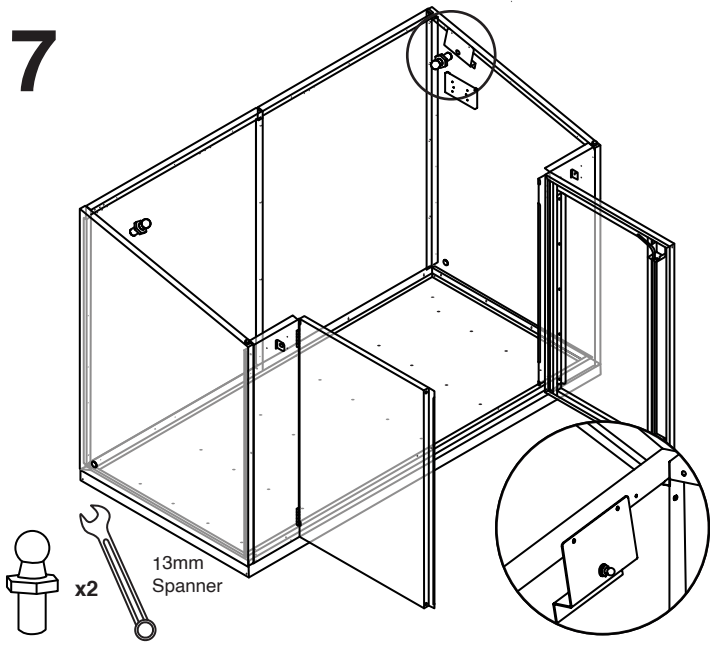

8

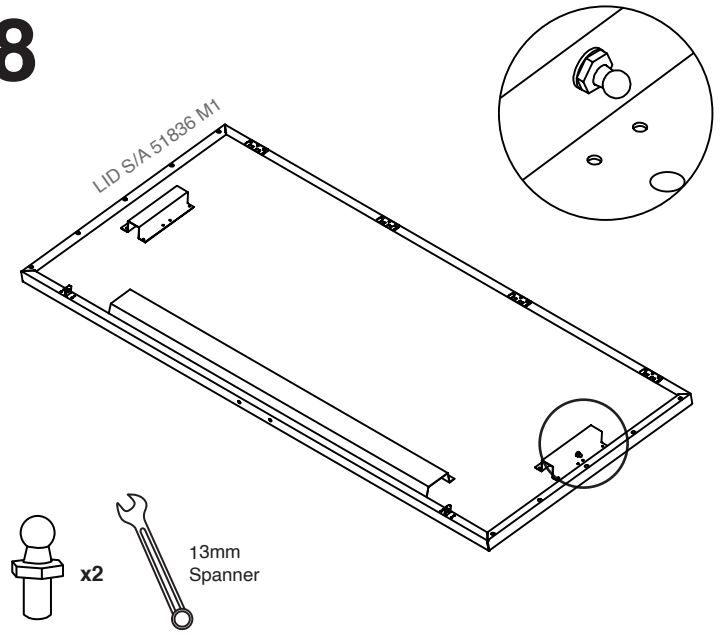

9

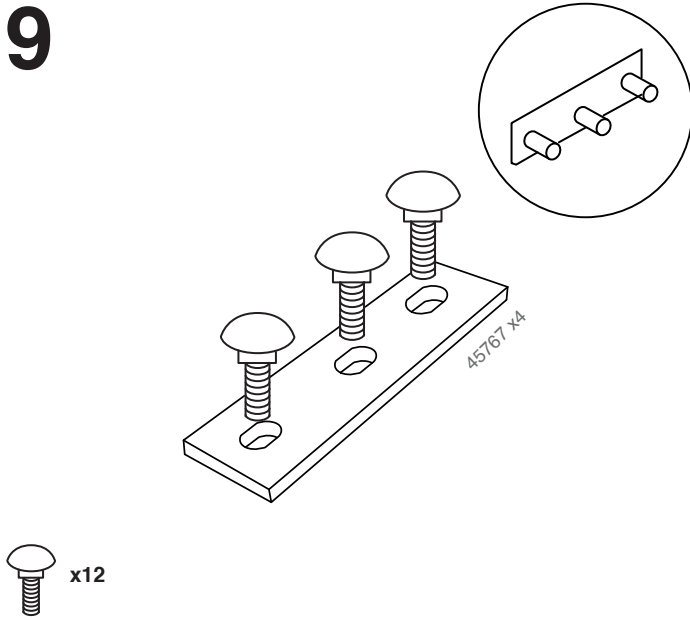

10

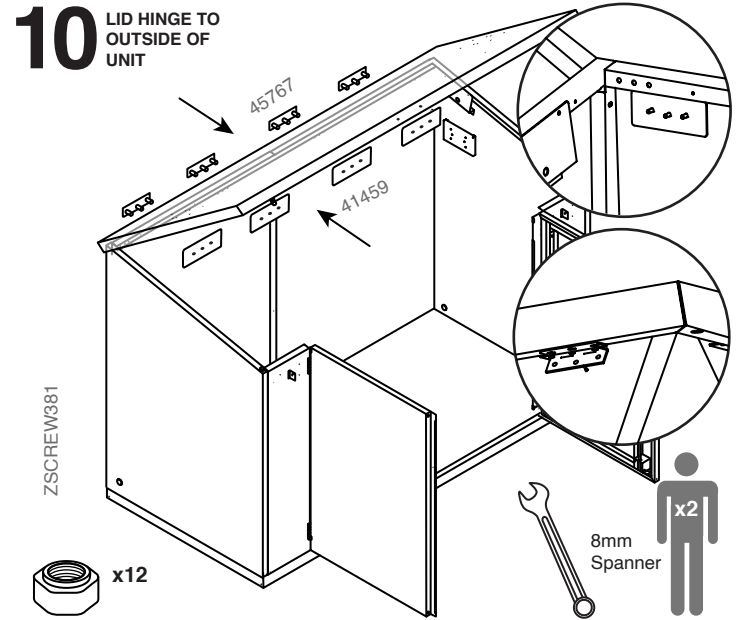

11

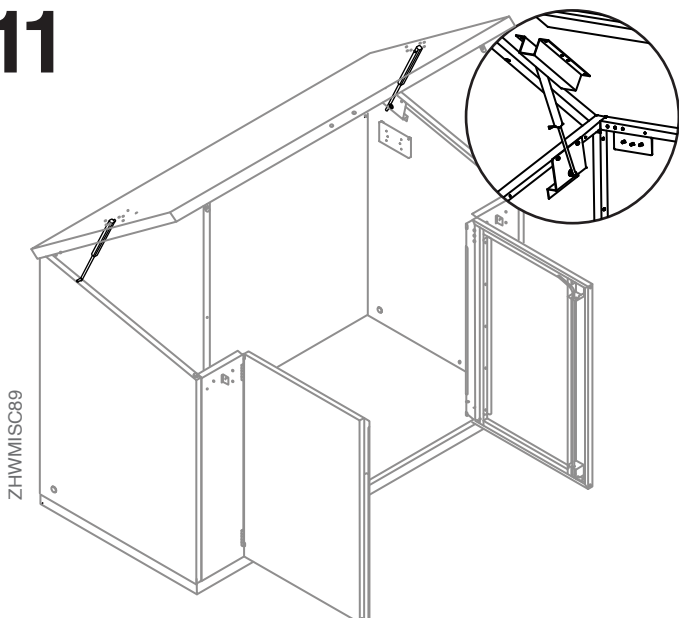

12

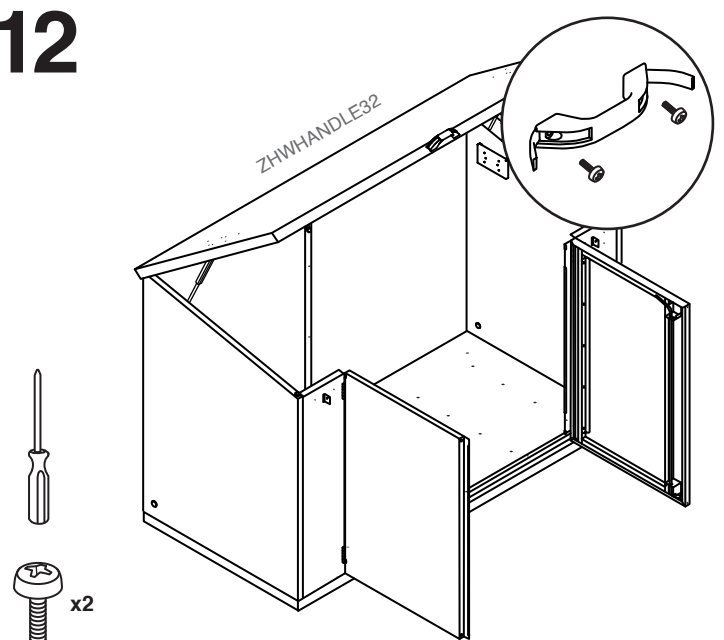

13! LEVEL SHED UNTIL DOORS
ALIGN USING ZCOMPLAS
AS SUITABLE

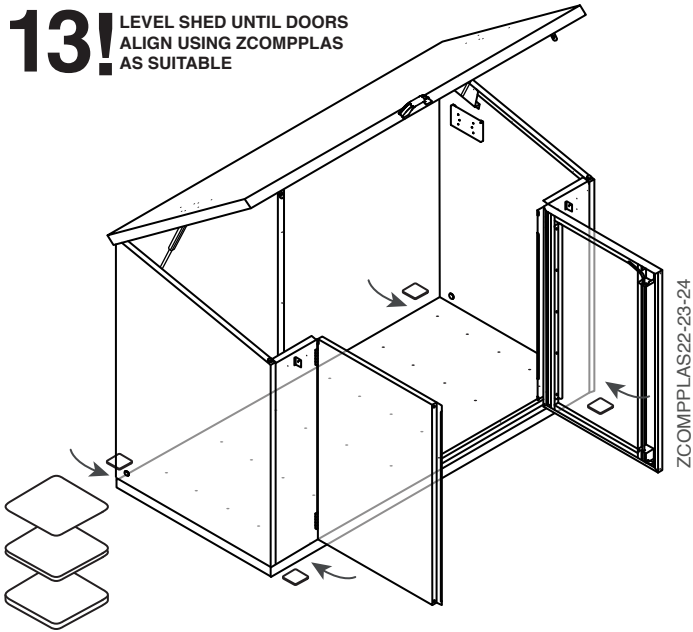

14

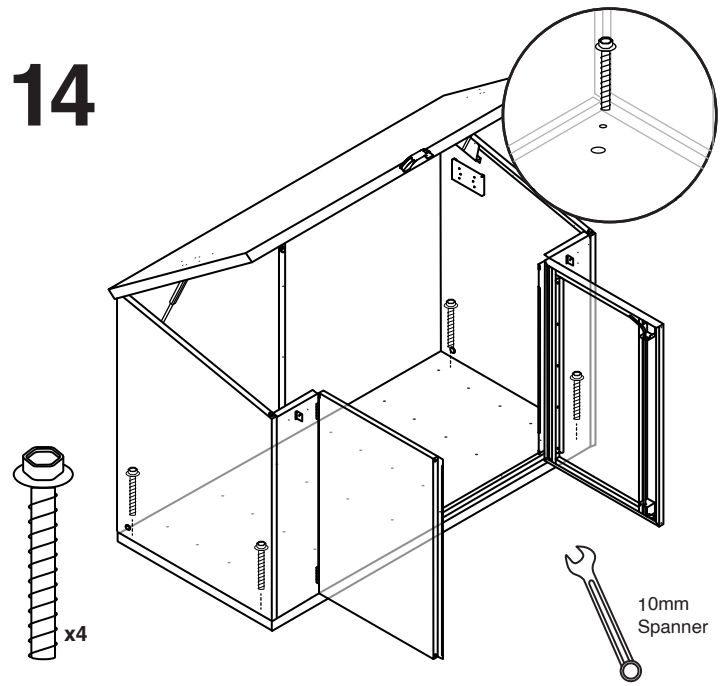

15! ENSURE CORRECT ALIGNMENT
BEFORE ATTACHING SHROUDS
(41824)

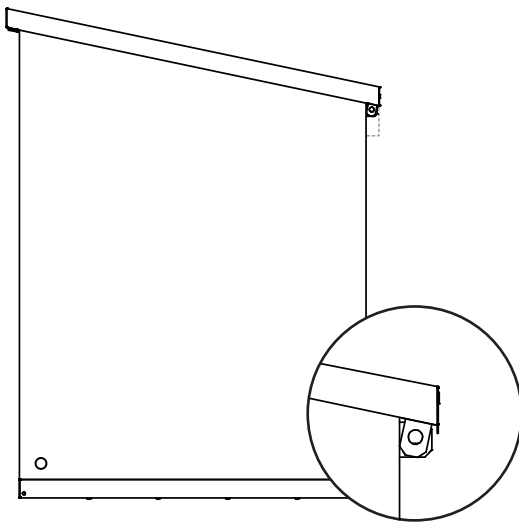

16! FIT SHROUDS (41824)
AS HIGH UP AS
POSSIBLE

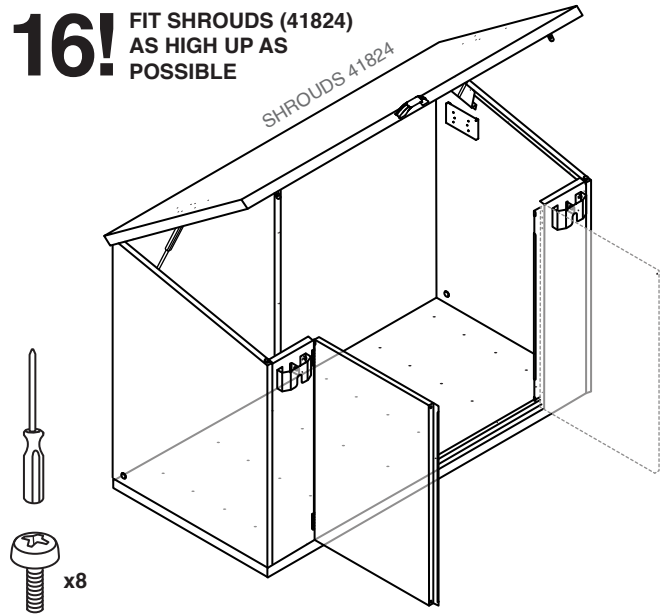

17! CHECK THE SHROUDS ARE
FLUSH WITH THE SHED

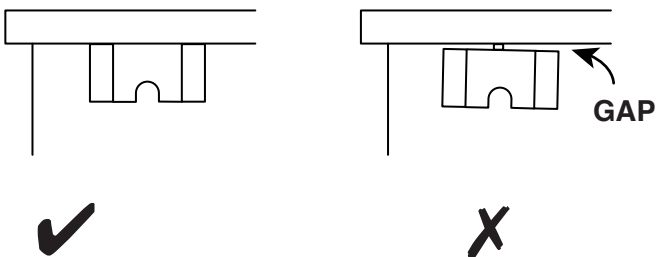

18! REMOVE SCREWS FROM
SIDE WHERE ELETRICS
ARE TO BE FITTED

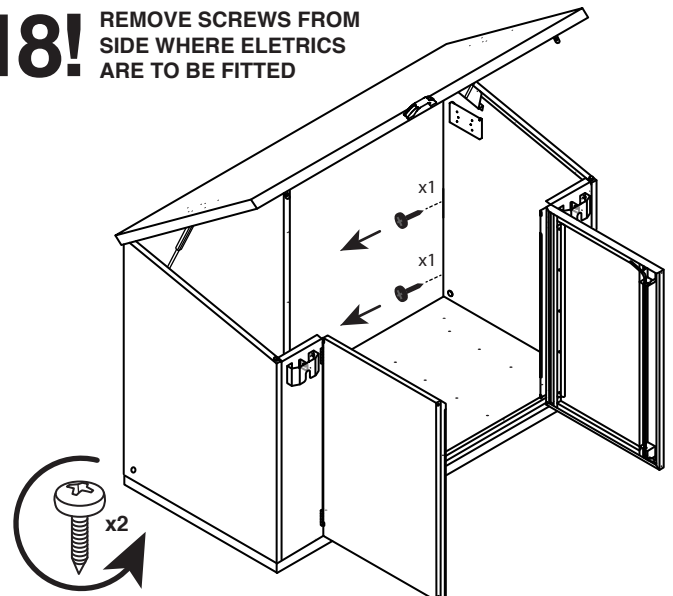

19!

**FIT EYELET BRACKET
TO RETAIN ELECTRIC
CABLES**

**FIT ELECTRICS TO MOUNTING
PLATE, MAY REQUIRE
ADDITIONAL DRILLING**

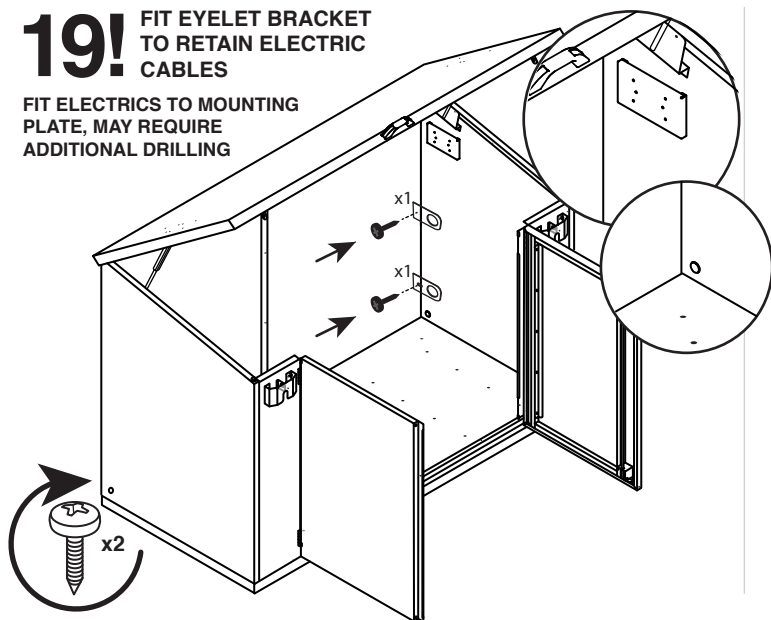

**YOU MUST ENSURE YOUR BASE IS LEVEL
AND THE LID ALIGNS CORRECTLY. YOU MUST
BOLT DOWN THE UNIT TO KEEP IT LEVEL.**

**YOU MUST USE THE DOOR PLUNGER/ BAR ON THE
BACK OF THE DOOR WHEN LOCKING YOUR SHED**

**FAILURE TO DO SO MAY MAKE
YOUR SHED LESS SECURE**