

GLADIATOR MOTORCYCLE



BASE INSTRUCTIONS

Flat and firm base. Recommended: concrete, tarmac or paving flags.
 Min. distance from walls/ shrubbery: 1000mm.
 Min. base size (WxDxH) 2410mm x 3100mm x 50mm.

LEVELING THE UNIT

Correctly level the constructed unit using the shims (ZCOMPPLAS) provided prior to fixing the unit to the ground. Slide the packing pieces under the corners of the unit base as required until an equal gap has been achieved around the door allowing for its smooth operation and alignment.

It is always recommended to anchor the unit in to the ground. Drill through the four holes in each of the bases of the unit using 6mm dia masonry drill to a depth of 70mm. Screw in the anchor fixings. (These have a self cutting thread). If not anchoring the unit, fit the self seal plugs BEFORE BUILDING to block the fixing holes from underneath.

Please note, product must be bolted down to comply with LPS1175.

TOOLS REQUIRED

Power driver POSI-DRIV screwdriver, 6mm dia. masonry drill and a 10mm socket or spanner.



Warning: some panels may weigh over 20Kg. Beware of manual handling

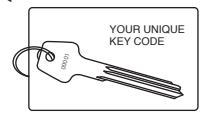
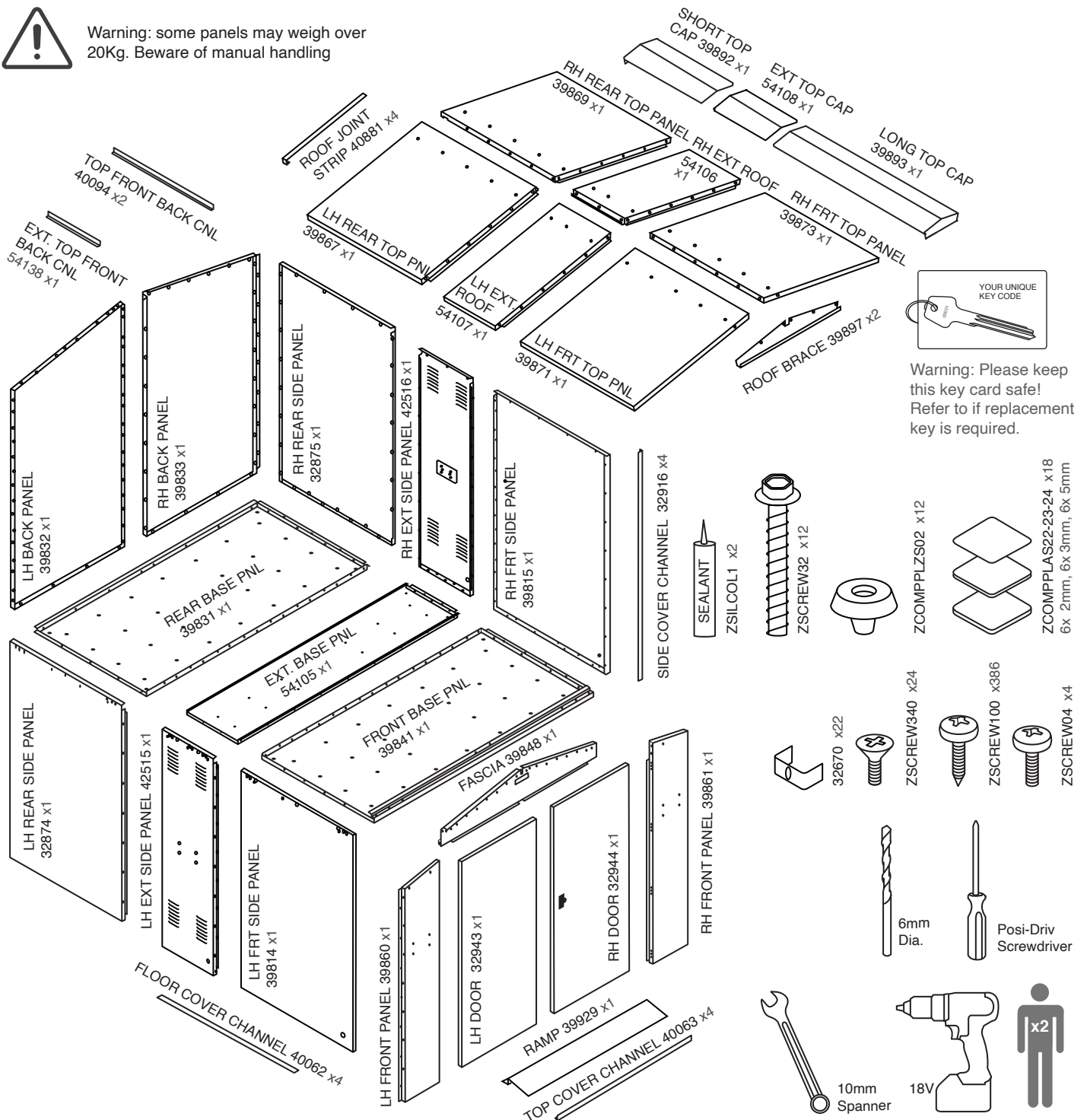

Warning: Please keep this key card safe! Refer to if replacement key is required.

PLEASE NOTE ALL SCREWS ARE FIXED FROM THE INSIDE

1

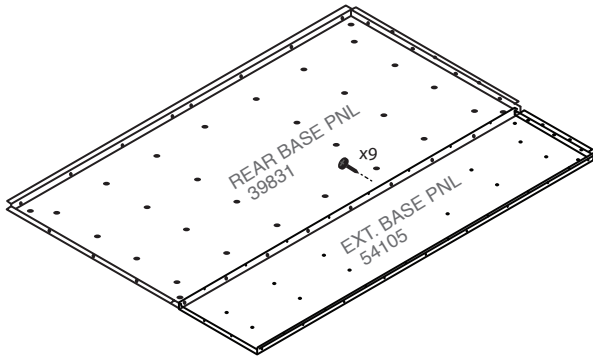

2! IF YOU HAVE AN OPTIONAL RAMP, PLACE UNDERNEATH FRONT BASE PANEL AT THIS STAGE

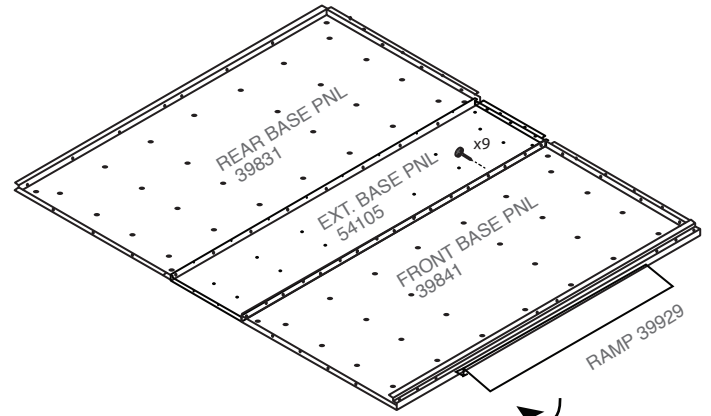

3

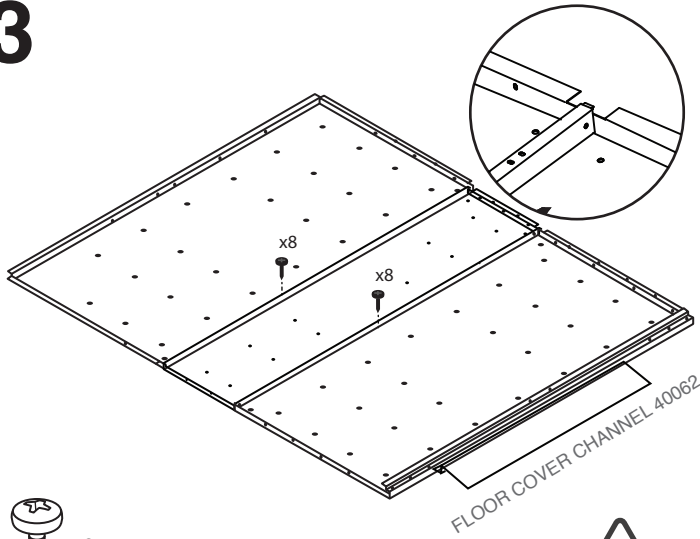

4

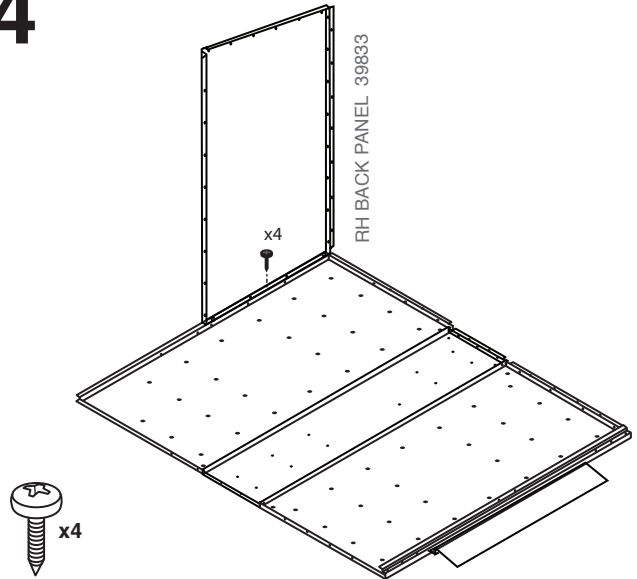

5

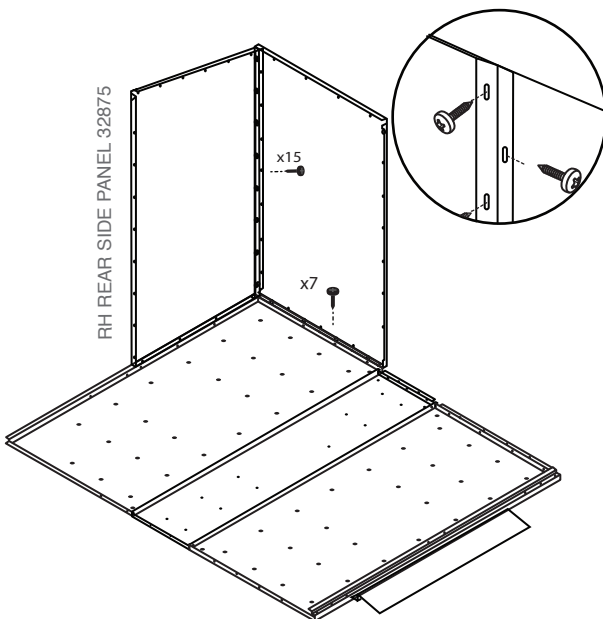

6

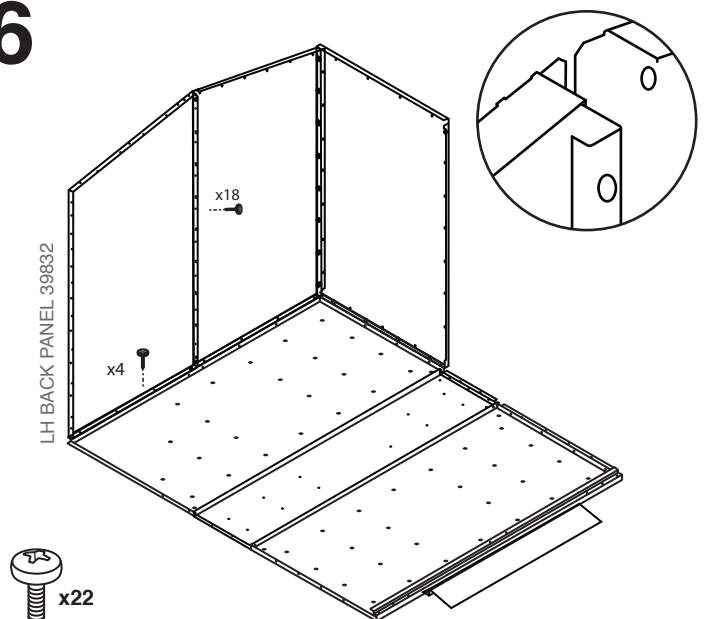

PLEASE NOTE ALL SCREWS ARE FIXED FROM THE INSIDE

7

LH REAR SIDE PANEL 32874

x15

x7



8

LH EXT SIDE PANEL 42515

RH EXT SIDE PANEL 42516

x7

x3



9

LH FRT SIDE PANEL
39814

RH FRT SIDE PANEL
39815

x7

x9

x9



10

SIDE COVER CHANNELS 32916 x4

x8

x8

x8



11

RH FRONT PANEL 39861
LH FRONT PANEL 39860

x15

x15

x3

x3



12

FASCIA 39848

x5

x5



PLEASE NOTE ALL SCREWS ARE FIXED FROM THE INSIDE

13

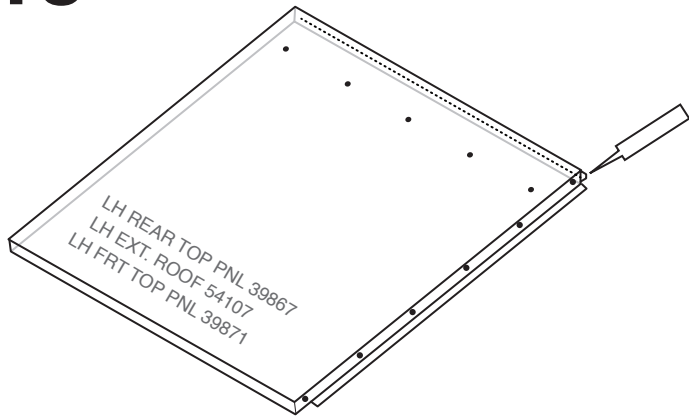

14

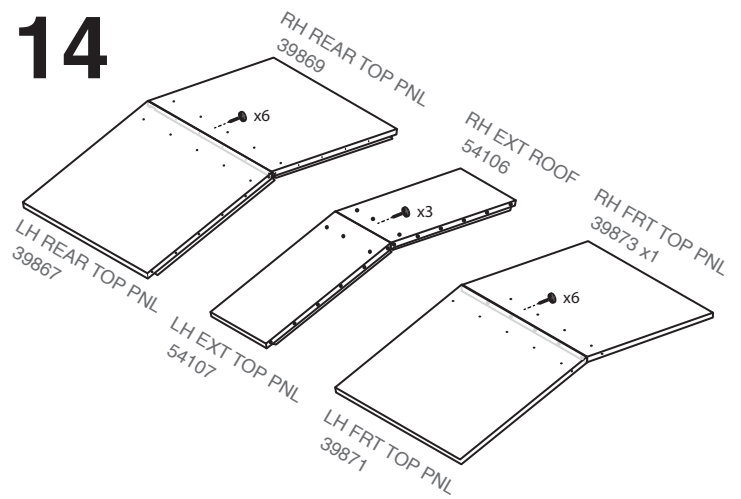

15!

PLEASE NOTE, THE CENTRAL ROOF SECTION REQUIRES 3 SCREWS ONLY

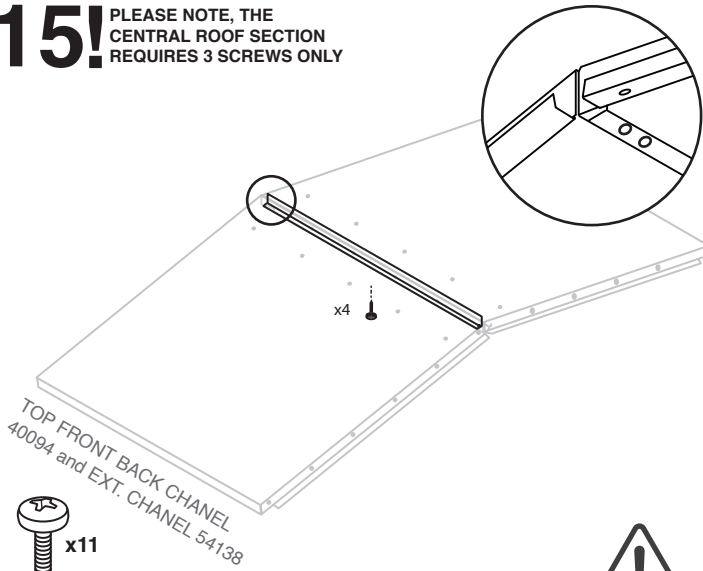

16

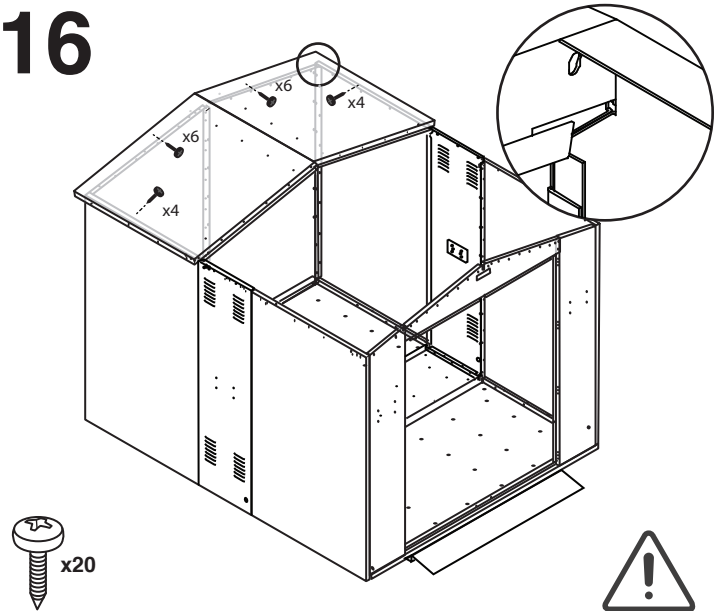

17

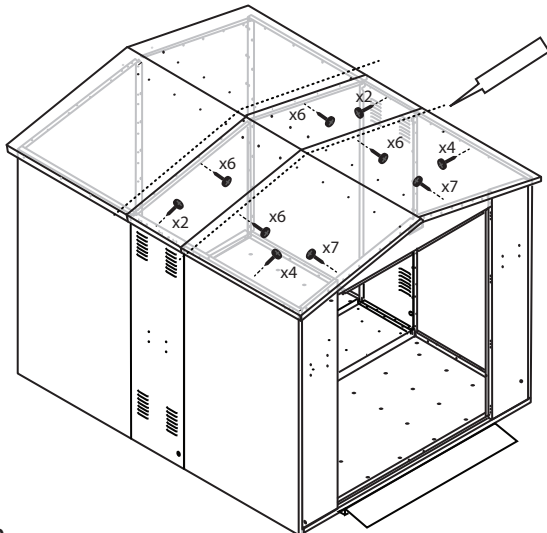

18

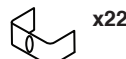
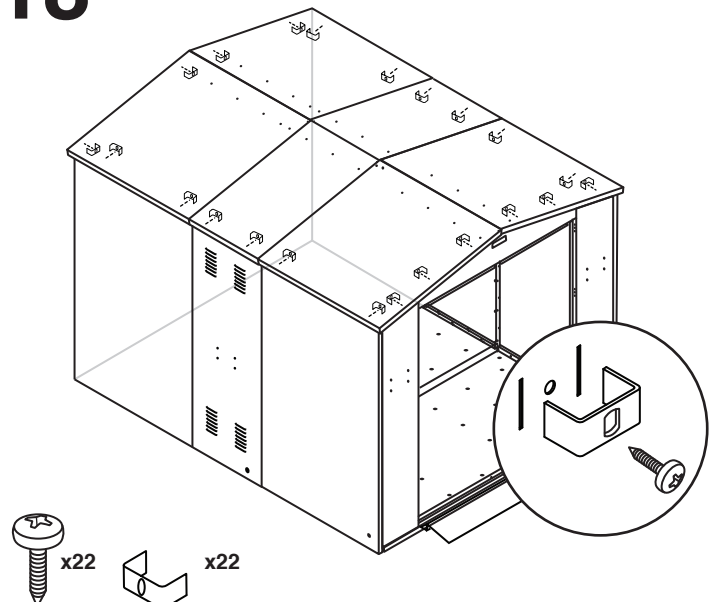

PLEASE NOTE ALL SCREWS ARE FIXED FROM THE INSIDE

19

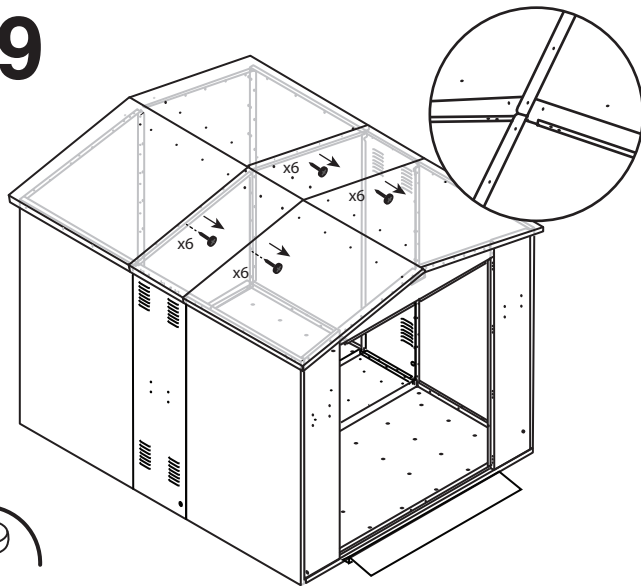

20

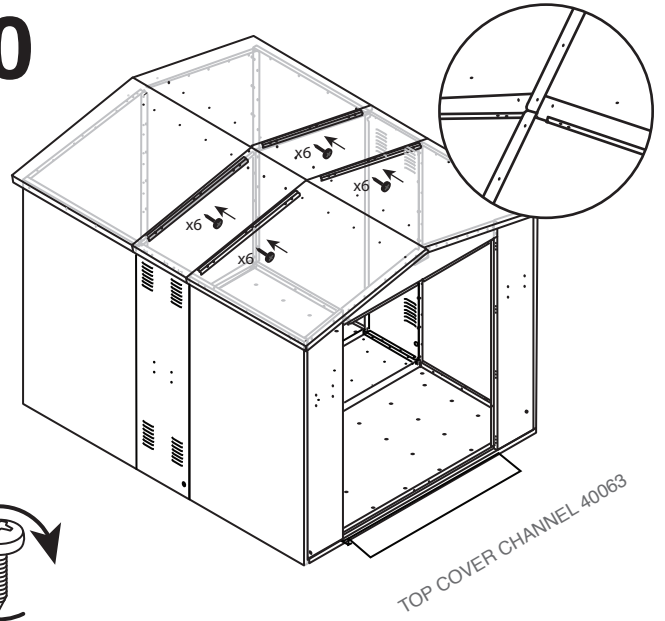

21

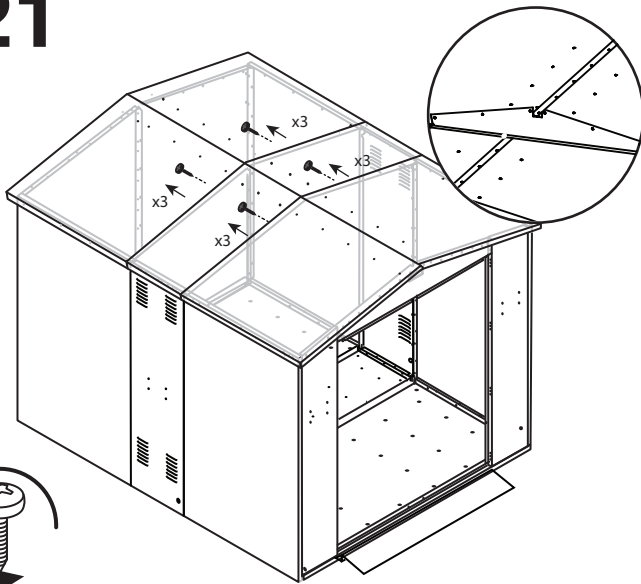

22

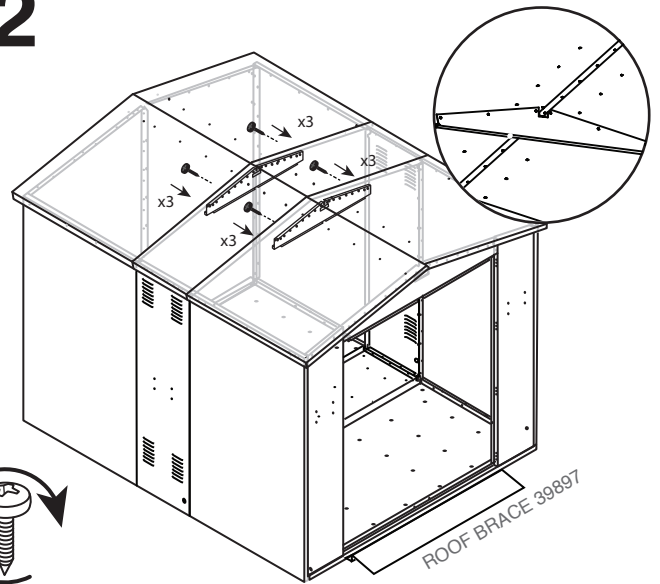

23

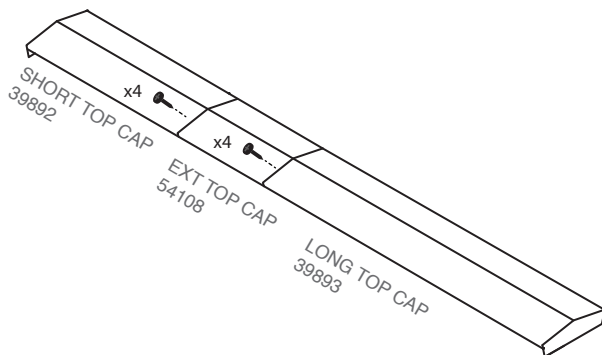

24!

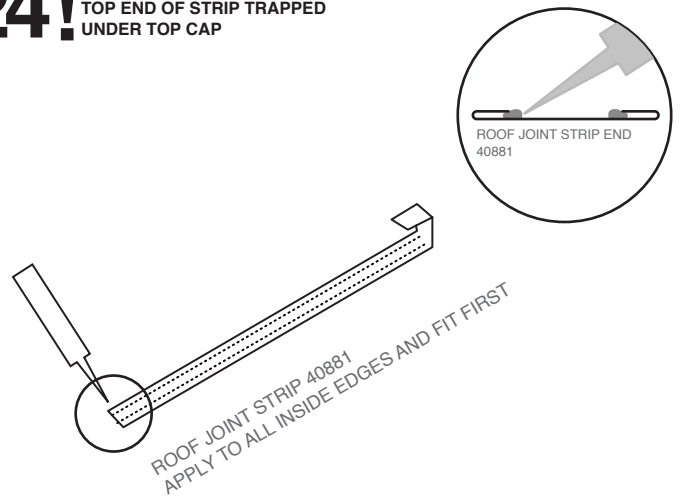
 NO SCREWS REQUIRED
TOP END OF STRIP TRAPPED
UNDER TOP CAP

PLEASE NOTE ALL SCREWS ARE FIXED FROM THE INSIDE

25

SHORT TOP CAP 39892
EXT TOP CAP 54108
LONG TOP CAP 39893

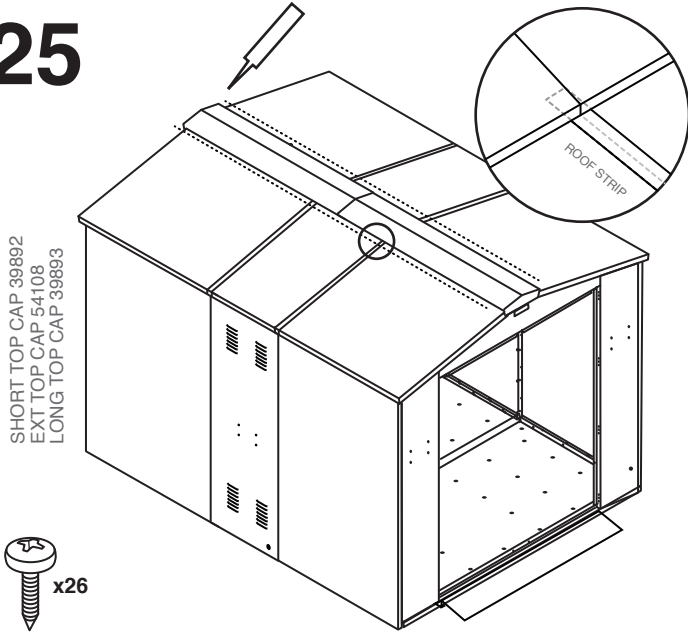

26

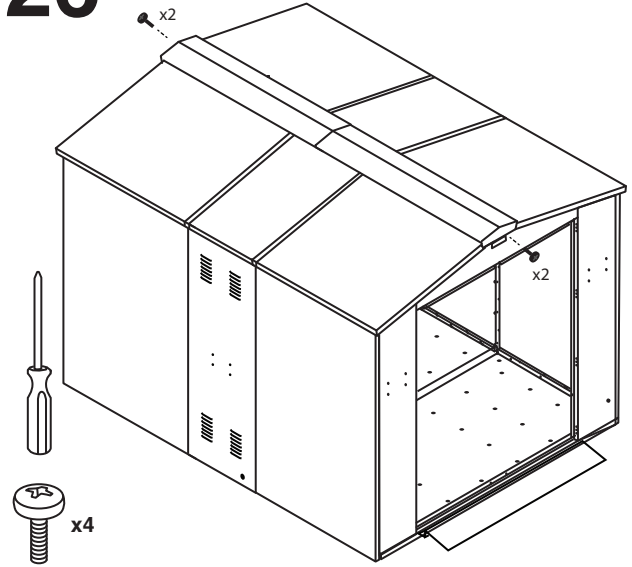

27

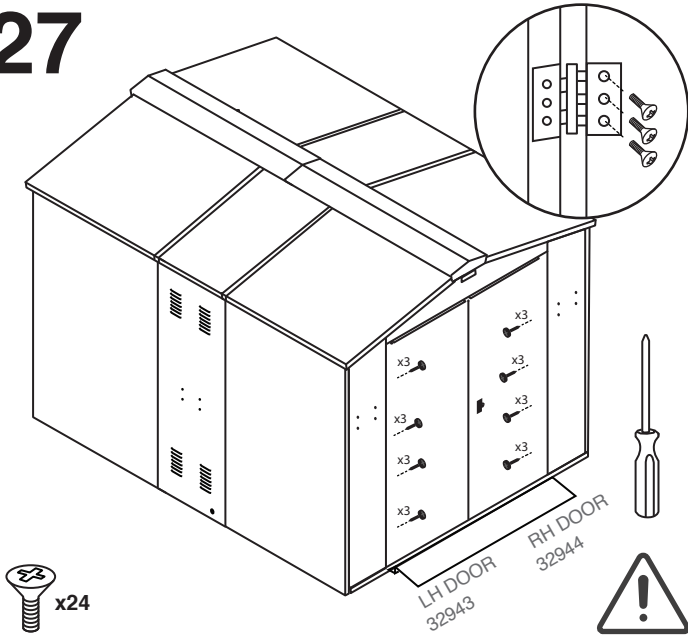

28! LEVEL SHED UNTIL DOORS
ALIGN USING ZCOMPLAS
AS SUITABLE

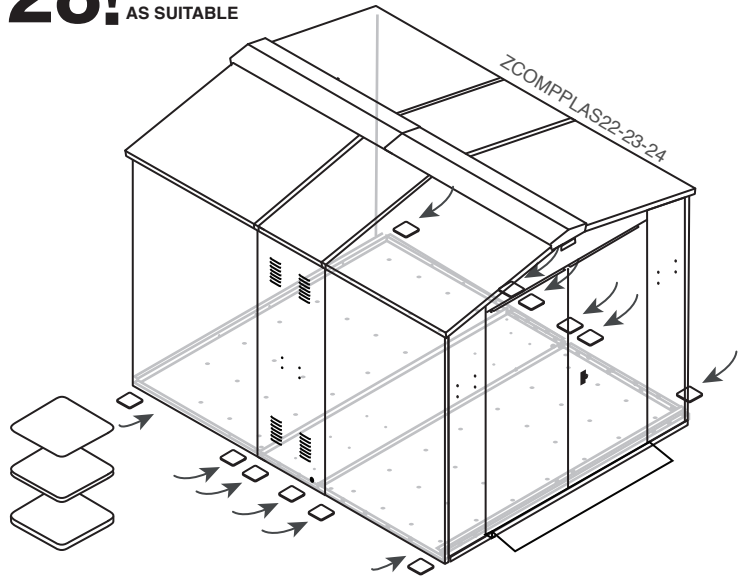

29

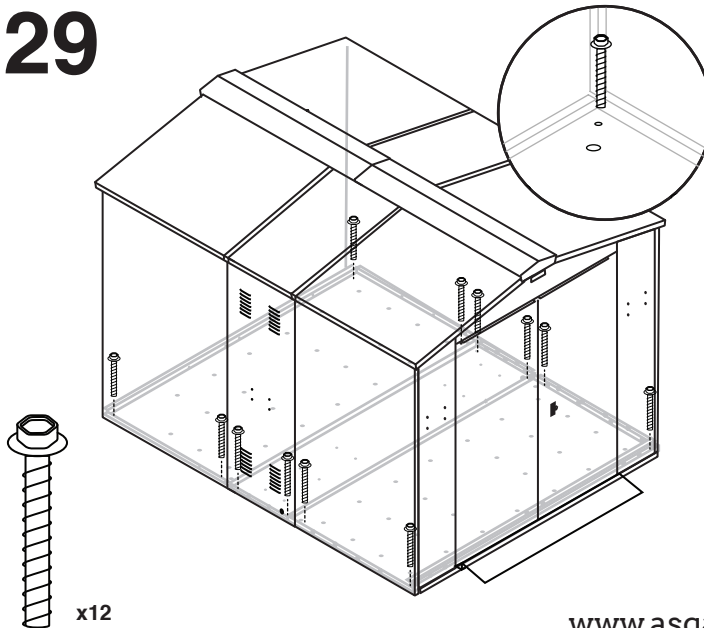

www.asgardsss.co.uk