

PARTS REQUIRED	INSTRUCTION
RH BACK PANEL ④ BASE PANEL ②	Position right hand back panel '4' into the channel on the base panel '2' so that fixing holes are aligned, the back panel should slightly overhang the base. Whilst one person holds the panels in place the other should screw the panels together.
5X	

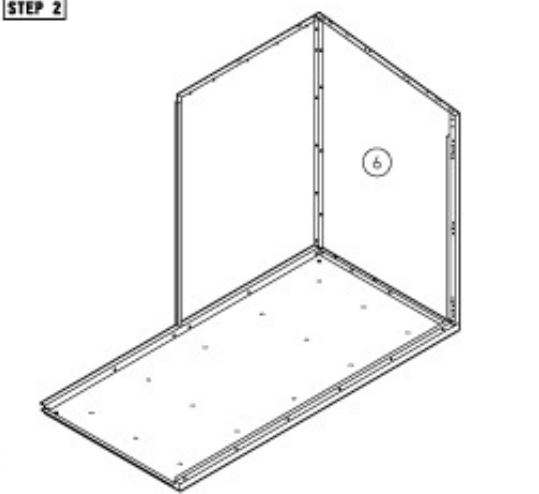

PARTS REQUIRED	INSTRUCTION
RH SIDE PANEL ⑥	Position the rh side panel '6' into the channel on the base panel, and up to the already fixed rh back panel ensuring the fixing holes are aligned, screw together.
19X	

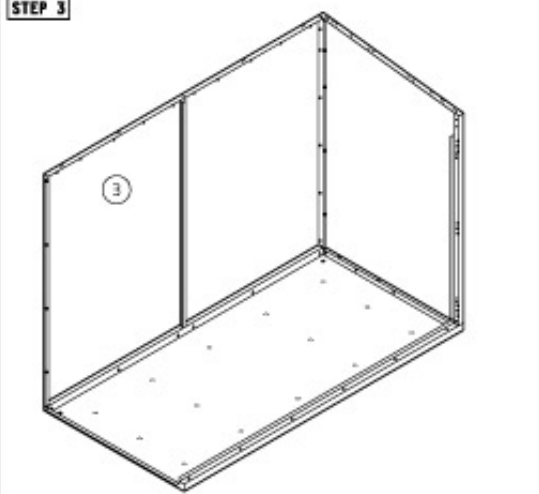

PARTS REQUIRED	INSTRUCTION
LH BACK PANEL ③	Locate LH back pnl '3' into base and LH back panel as shown. Screw together down full length of vertical joint and across the base.
16X	

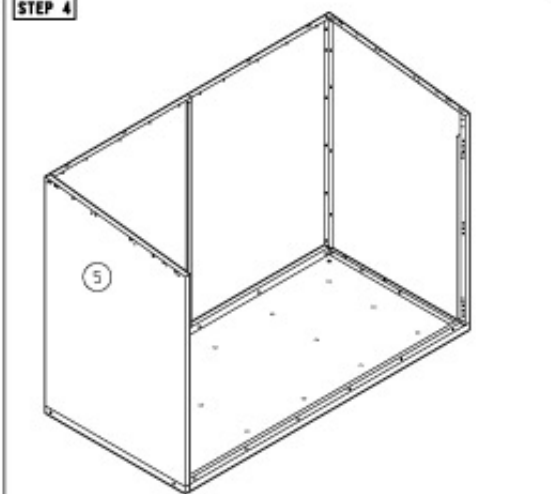

PARTS REQUIRED	INSTRUCTION
LH SIDE PANEL ⑤	Position LH side '5' to LH back panel and base as indicated, ensuring the holes are aligned screw together.
18X	

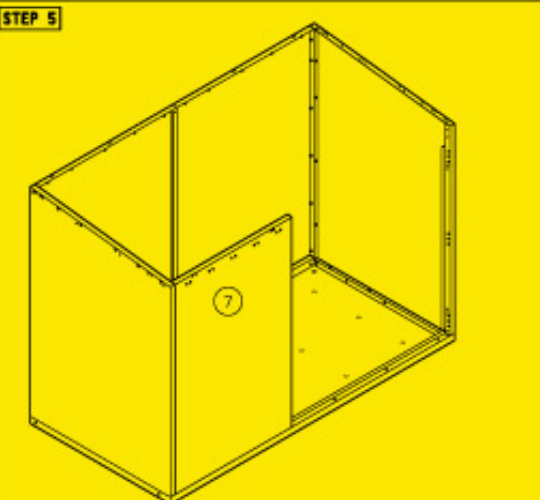

PARTS REQUIRED	INSTRUCTION
FRONT PANEL ⑦	At this stage it is important to determine on which side you wish to hang the doors from. If you require the doors to be fitted on the RH side of the unit then fit the front panel on the LH side (as shown). If you wish to fit the doors on the LH side of the unit then fit the front panel to the RH side of the unit. Position front pnl '7' as shown (at desired side of unit). Screw to side and base panel.
8X	

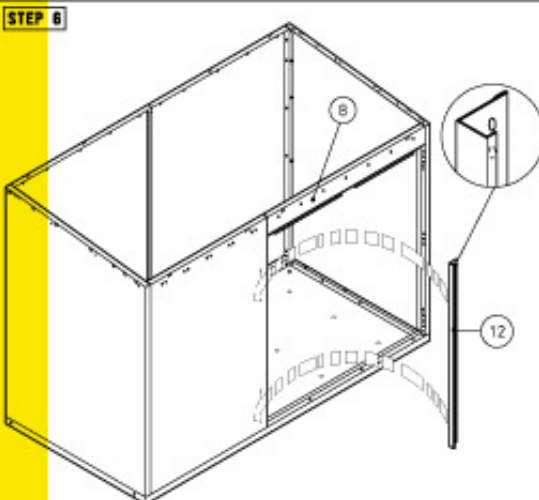

PARTS REQUIRED	INSTRUCTION
FASCIA ⑧ FRONT PANEL TRAP PLATE ⑫	Attach fascia panel '8' across the front of the unit as shown, screw to front panel and side panel (requires 8 screws) From inside the unit attach the front trap plate '12' down the full length of the front panel. (requires 7 screws)
15X	

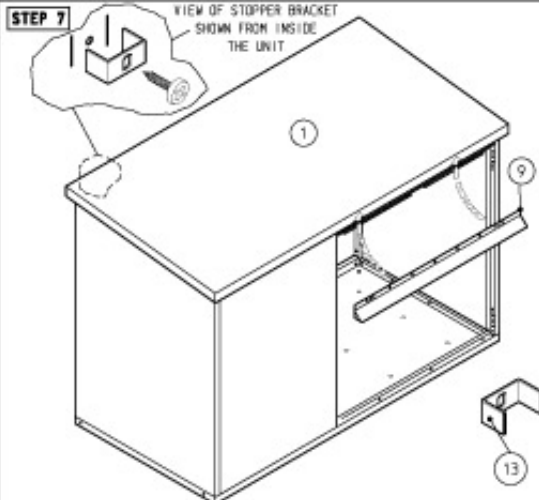

PARTS REQUIRED	INSTRUCTION
TOP PANEL ① RAIN GUARD ⑨ STOPPER BRACKET ⑬	LIFT top panel '1' onto unit, over the outer panels and fascia, ensuring that the Aggerd Stronghold badge is on the front RH side and the ventilation holes are at the back. Slide the reainguard '9' under the top panel, over the fascia, centralise it, and screw through the fascia and into the top (from inside the unit). Having positioned the top and fitted the fascia, fit the stopper brkts '13' to the inside of the unit, these brackets locate into the pairs of slots on the top of each of the panels with the lugs on these pointing outer-most end and are each fixed with a single screw. (finally fit the remaining top panel screws)
41X	

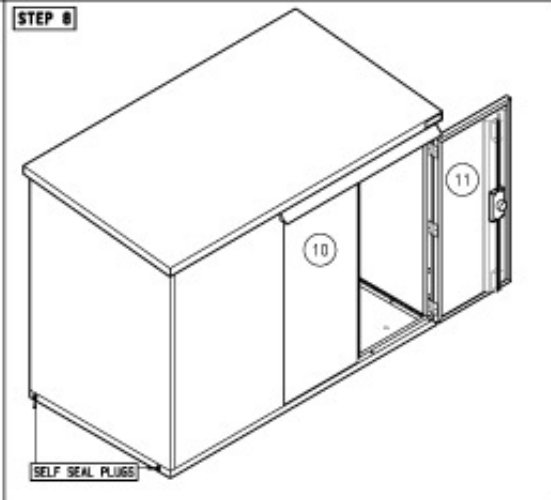

PARTS REQUIRED	INSTRUCTION
RH DOOR ⑪ LH DOOR ⑩	WE ADVISE THAT YOU USE HAND HELD DRIVERS RATHER THAN POWER DRIVERS WHEN FIXING THE DOORS. IT IS IMPORTANT TO SUPPORT THE DOORS AT ALL TIMES WHILST FITTING THE SCREWS, TO ENSURE CORRECT ALIGNMENT. Position LH door '10' (non locking door) so that hinges are aligned with fixing holes screw in position. (LH door shown in position) Position RH door '11' (locking door) so that hinges are aligned with fixing holes, screw in position. FIT FOUR SELF SEAL PLUGS INTO THE HOLES IN THE SIDES OF THE BASE PANEL TO PREVENT WATER INGRESS.
18X	
4X	